

INDEX OF DRAWING	
SHEET NO.	DESCRIPTION
1	COVER PAGE, GENERAL NOTES, GLAZING DETAILS
2 & 2.1	SINGLE & DOUBLE DOORS TYP. ELEVATIONS & CAPACITY
3	SINGLE & DOUBLE DOORS WITH TRANSOM, ELEVATIONS & CAPACITY CHART
4 & 4.1	LOCK OPTIONS & LIMITATIONS
5	HORIZONTAL RAILS, HEAD/SILL DETAILS & TYPICAL ANCHORS
5.1	ADA COMPLIANT THRESHOLD DETAILS
6	VERTICAL STILES, JAMB DETAILS
7	TRANSOM HEAD/SILL/JAMB DETAILS
8	PARTS DRAWINGS
9	BILL OF MATERIALS & HINGE OPTIONS
10	CORNER CONSTRUCTION DETAILS

**SERIES ENV-350
ALUMINUM INSWING ENTRANCE DOOR**

DOORS NOT APPROVED FOR INSTALLATIONS WHERE WATER INFILTRATION RESISTANCE IS REQUIRED.

THESE DOORS MAY BE USED IN CONJUNCTION WITH F.B.C. APPROVED LARGE MISSILE IMPACT RESISTANT STOREFRONT SYSTEM. LOWER DESIGN PRESSURE FROM DOOR OR STOREFRONT APPROVAL WILL APPLY TO ENTIRE SYSTEM.

CODE REQUIREMENTS FOR SAFEGUARDS MUST BE OBSERVED.

THIS PRODUCT HAS BEEN DESIGNED AND TESTED TO COMPLY WITH THE REQUIREMENTS OF THE 2014 (5TH EDITION)/2017 (6TH EDITION) FLORIDA BUILDING CODE INCLUDING HIGH VELOCITY HURRICANE ZONE (HVHZ).

1BY OR 2BY WOOD BUCKS & BUCK FASTENERS BY OTHERS, MUST BE DESIGNED AND INSTALLED ADEQUATELY TO TRANSFER APPLIED PRODUCT LOADS TO THE BUILDING STRUCTURE.

ANCHORS SHALL BE CORROSION RESISTANT, SPACED AS SHOWN ON DETAILS AND INSTALLED PER MANUF'S INSTRUCTIONS. SPECIFIED EMBEDMENT TO BASE MATERIAL SHALL BE BEYOND WALL DRESSING OR STUCCO.

A LOAD DURATION INCREASE IS USED IN DESIGN OF ANCHORS INTO WOOD ONLY.

ALL SHIMS TO BE HIGH IMPACT, NON-METALLIC AND NON-COMPRESSIBLE.

MATERIALS INCLUDING BUT NOT LIMITED TO STEEL/METAL SCREWS, THAT COME INTO CONTACT WITH OTHER DISSIMILAR MATERIALS SHALL MEET THE REQUIREMENTS OF THE 2014/2017 FLORIDA BLDG. CODE & ADOPTED STANDARDS.

THIS PRODUCT APPROVAL IS GENERIC AND DOES NOT PROVIDE INFORMATION FOR A SITE SPECIFIC PROJECT, i.e. LIFE SAFETY OF THIS PRODUCT, ADEQUACY OF STRUCTURE RECEIVING THIS PRODUCT AND SEALING AROUND OPENING FOR WATER INFILTRATION RESISTANCE ETC. CONDITIONS NOT SHOWN IN THIS DRAWING ARE TO BE ANALYZED SEPARATELY, AND TO BE REVIEWED BY BUILDING OFFICIAL.

MANUFACTURER'S LABEL SHALL BE LOCATED ON A READILY VISIBLE LOCATION IN ACCORDANCE WITH SECTION 1709.9.3 OF FLORIDA BUILDING CODE. LABELING TO COMPLY WITH SECTION 1709.9.2.

INSTRUCTIONS:

USE DRAWING AS FOLLOWS.

1. SELECT SINGLE OR DOUBLE DOORS FROM SHEETS 2 & 2.1 OR SINGLE OR DOUBLE DOORS WITH TRANSOM FROM SHEET 3.
2. SELECT DOOR AND FRAME SIZE.
3. DETERMINE Dp RATING FROM SHEET 2, 2.1 OR 3.
4. SELECT GLASS TYPE FROM SHEET 1.1.
5. SELECT LOCK OPTION AND CORRESPONDING MAX. DESIGN LOAD FROM SHEET 4 & 4.1.
6. SELECT ANCHORING CONDITION AND CORRESPONDING ANCHOR TYPE AND NUMBER OF ANCHORS FROM SHEET 5.
7. SELECT JAMB OPTIONS FROM SHEET 6.
8. SELECT HINGE OPTION FROM SHEET 9.
9. DETERMINE FINAL DESIGN PRESSURE FOR THE SYSTEM, TAKEN AS THE LOWEST OF ALL Dp VALUES OBTAINED.

DOORS ARE RATED FOR LARGE & SMALL MISSILE IMPACT. SHUTTERS ARE NOT REQUIRED.

A- CONTRACTOR TO BE RESPONSIBLE FOR THE SELECTION, PURCHASE AND INSTALLATION OF THIS PRODUCT BASED ON THIS PRODUCT EVALUATION PROVIDED HE/SHE DOES NOT DEVIATE FROM THE CONDITIONS DETAILED ON THIS DOCUMENT.
 B- THIS PRODUCT EVALUATION DOCUMENT WILL BE CONSIDERED INVALID IF ALTERED BY ANY MEANS.
 C- SITE SPECIFIC PROJECTS SHALL BE PREPARED BY A FLORIDA REGISTERED ENGINEER OR ARCHITECT WHICH WILL BECOME THE ENGINEER OF RECORD (E.O.R.) FOR THE PROJECT AND WHO WILL BE RESPONSIBLE FOR THE PROPER USE OF THE P.E.D. ENGINEER OF RECORD, ACTING AS A DELEGATED ENGINEER TO THE P.E.D. ENGINEER SHALL SUBMIT TO THIS LATTER THE SITE SPECIFIC DRAWINGS FOR REVIEW.
 D- THIS P.E.D. SHALL BEAR THE DATE AND ORIGINAL SEAL AND SIGNATURE OF THE PROFESSIONAL ENGINEER OF RECORD THAT PREPARED IT.

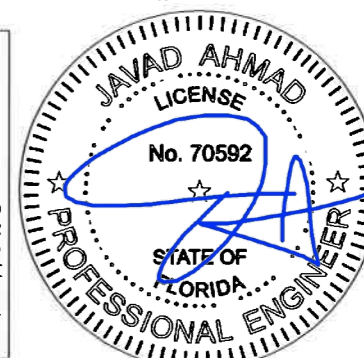

FL #20701

Sealed: 07/28/2017

a f c
AL-FAROOQ CORPORATION
 ENGINEERS & PRODUCT DEVELOPMENT
 9360 SUNSET DRIVE, SUITE 220
 MIAMI, FLORIDA 33173 (C.A.N. 353B)
 TEL. (305) 264-8100 FAX. (305) 262-6978
 COMP-ANL\W17-43ENV

SERIES ENV-350 INSWING ENTRANCE DOOR (L.M.I.)
ENVIRALUM INDUSTRIES INC.
 5100 N.W. 72 AVENUE BLDG. C
 MIAMI, FL. 33166
 TEL. (305) 752-4411 FAX. (305) 406-3877

revisions:	no	date	by	description
	A	07.06.17		GLASS & LOCK OPTION ADDED

date:	04-11-17
scale:	3/8" = 1"
dr. by:	TARIQ
chk. by:	

drawing no.
W17-43
 sheet 1 of 10

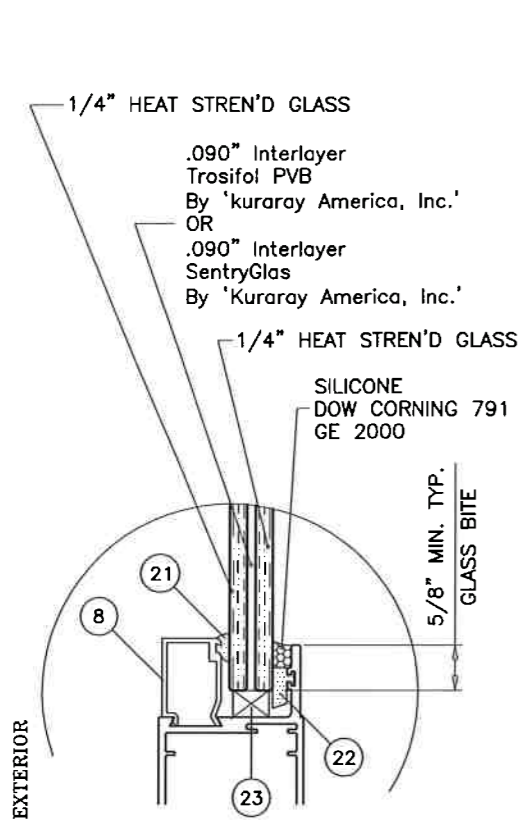

GLASS TYPE 'A'

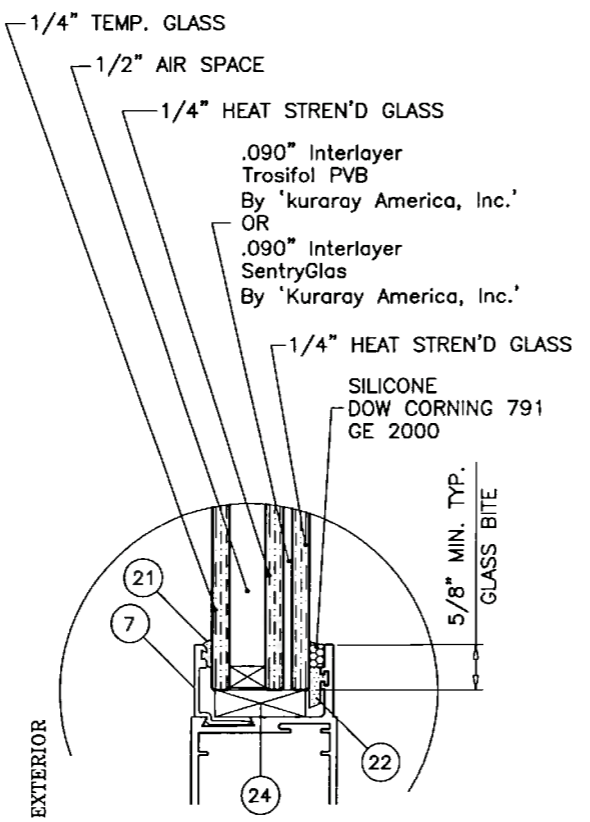

GLASS TYPE 'A1'

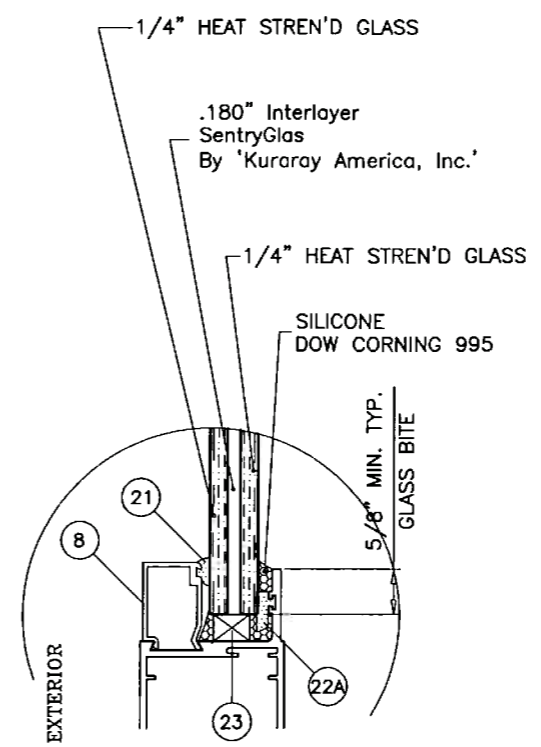

GLASS TYPE 'B'

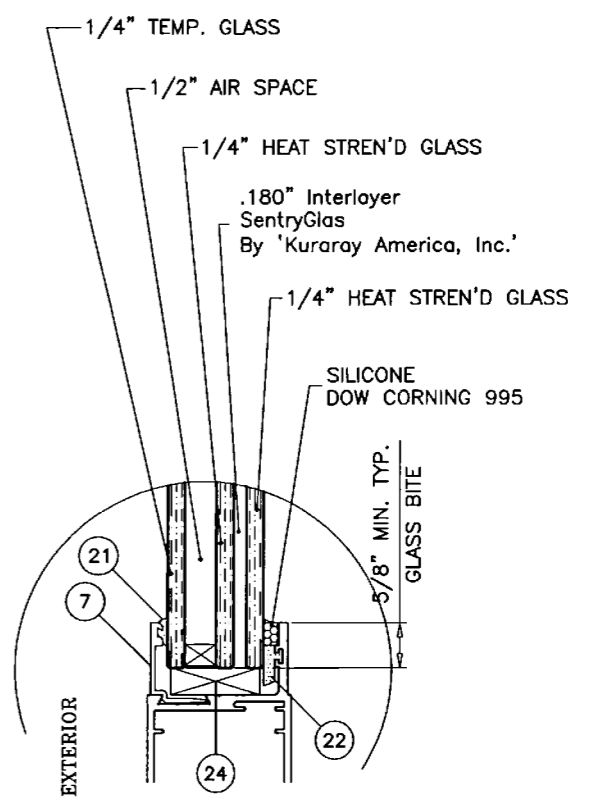

GLASS TYPE 'B1'

GLAZING DETAILS DOOR
LEVEL 'D' IMPACT

GLAZING DETAILS DOOR
LEVEL 'E' IMPACT

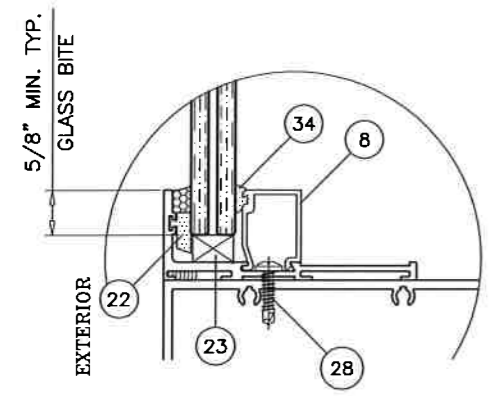

GLASS TYPE 'A'

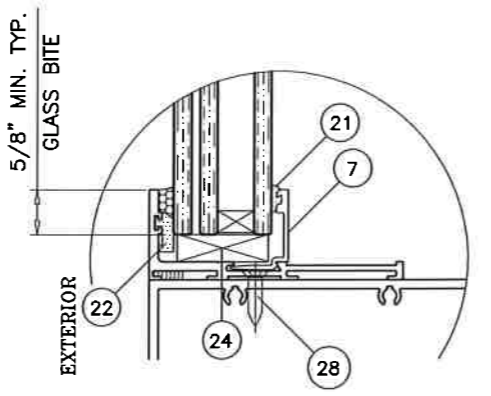

GLASS TYPE 'A1'

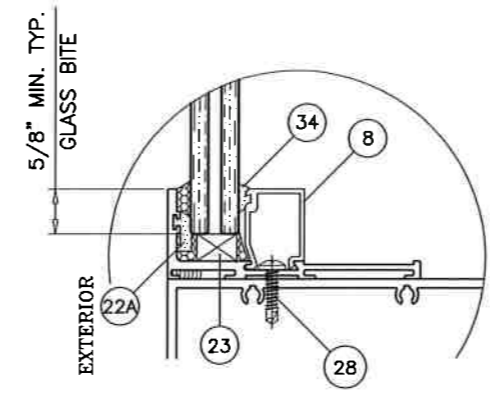

GLASS TYPE 'B'

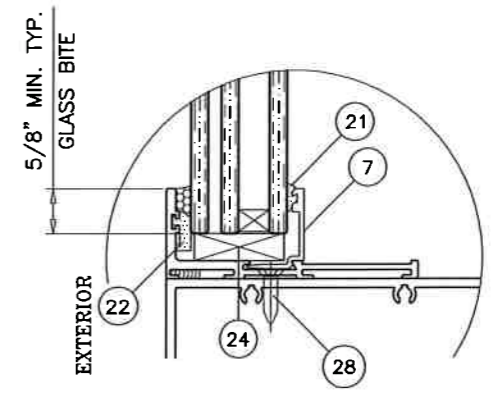

GLASS TYPE 'B1'

GLAZING DETAILS TRANSOM
LEVEL 'D' IMPACT

GLAZING DETAILS TRANSOM
LEVEL 'E' IMPACT

1/2" AIR SPACE CONSISTING OF:
SPACER:
ALUMINUM BOX SPACER AROUND
THE PERIMETER OF THE GLASS.
PERIMETER SEALANT:
SILICONE
DOW CORNING 791
GE 2000

Sealed: 07/28/2017

FL #20701

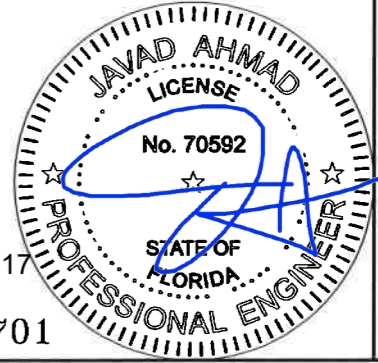

af c
AL-FAROOQ CORPORATION
ENGINEERS & PRODUCT DEVELOPMENT
9360 SUNSET DRIVE, SUITE 220 (C.A.N. 3538)
MIAMI, FLORIDA 33173 TEL. (305) 262-6978
FAX. (305) 264-8100

SERIES ENV-350 INSWING ENTRANCE DOOR (L.M.I.)
ENVRALUM INDUSTRIES INC.
5100 N.W. 72 AVENUE BLDG. C
MIAMI, FL. 33166
TEL. (305) 752-4411 · FAX. (305) 406-3877

revisions:	no	date	by	description

date: 04-11-17
scale: 3/8" = 1"
dr. by: TARIQ
chk. by:

drawing no.
W17-43
sheet 1.1 of 10

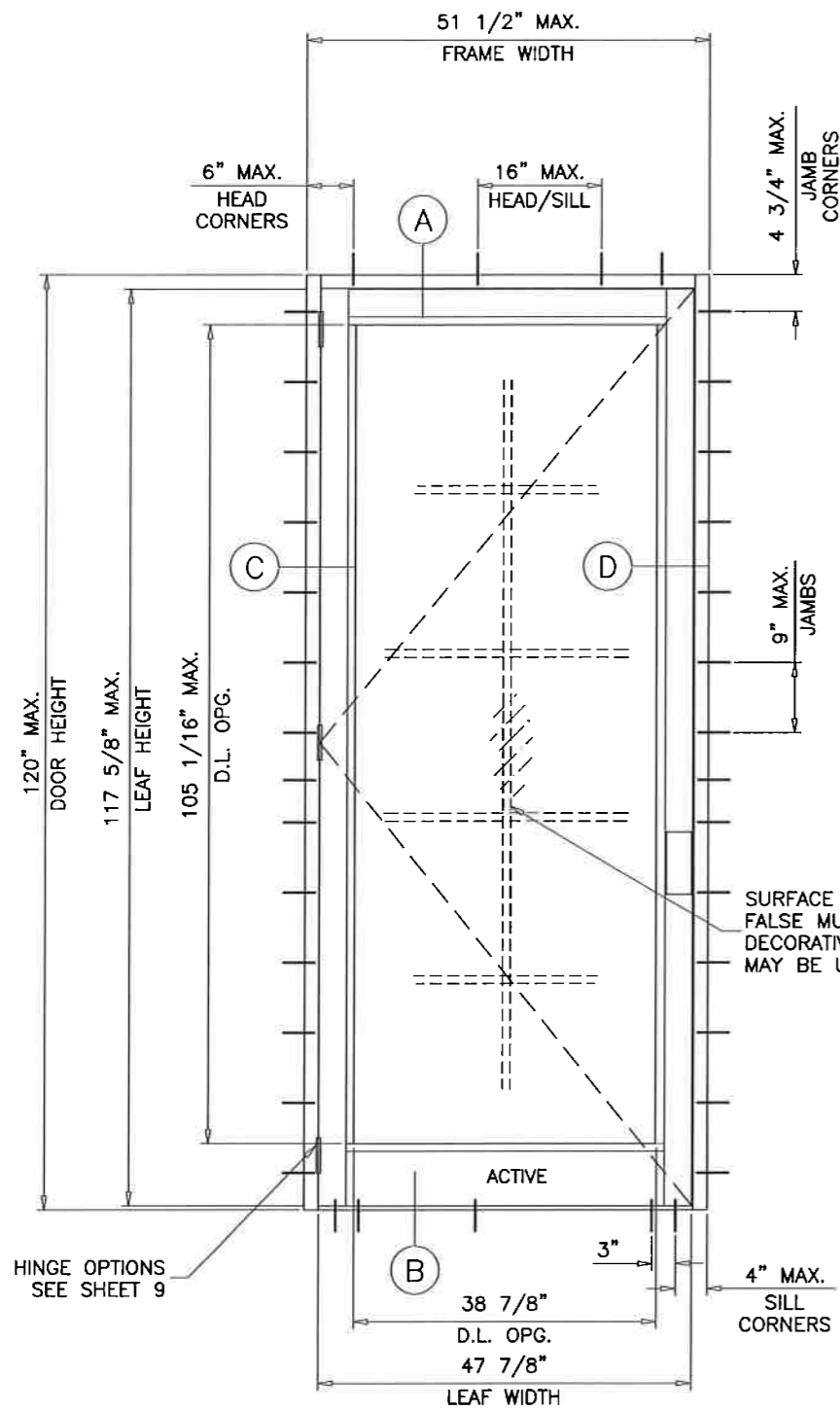

ANCHOR TYPES	NO. OF ANCHORS AT MTG. STILE ENDS	
	1/4" SHIM	3/8" SHIM
A	6	8
B	6	8
C	5	6

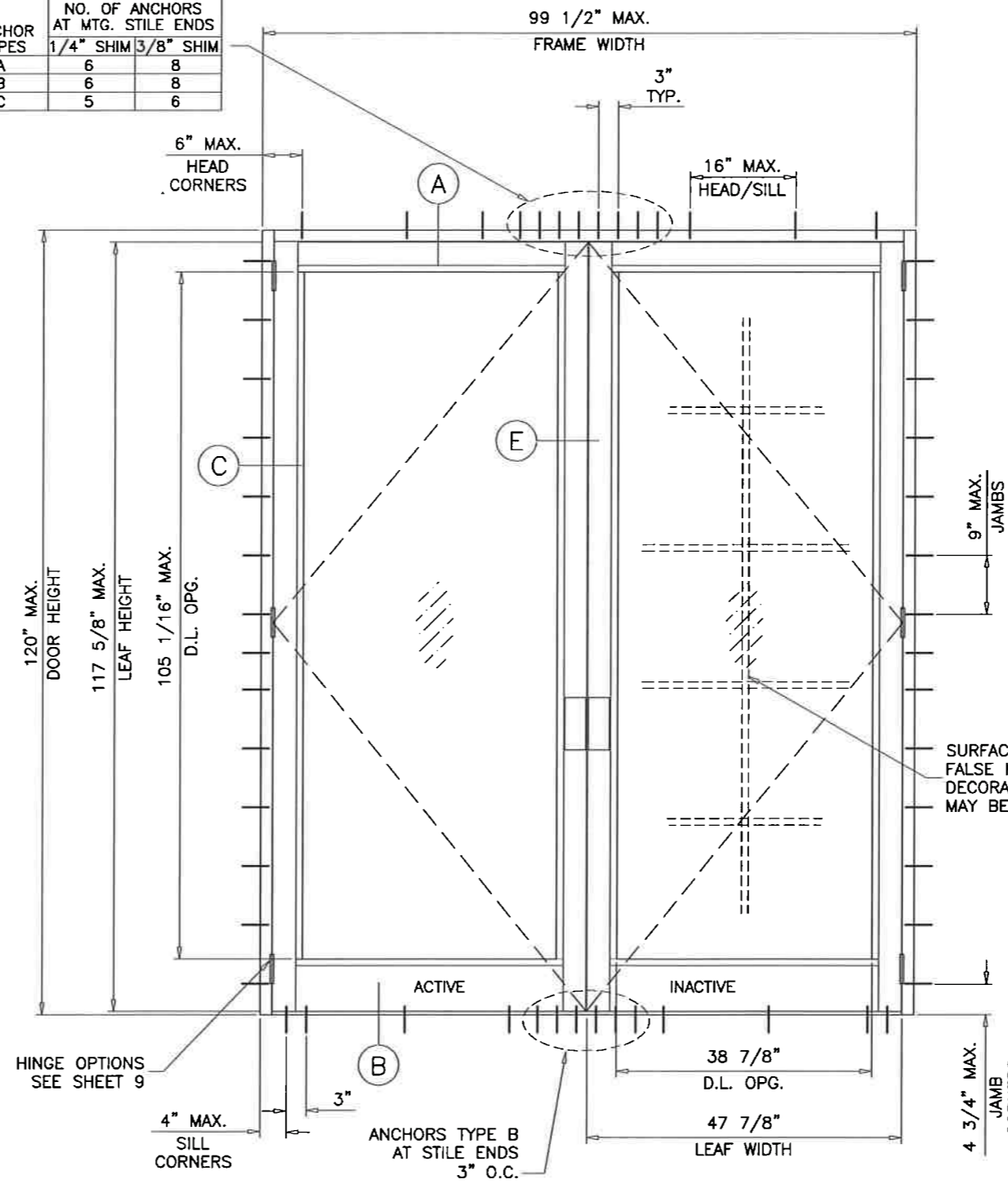

(X)

LEVEL 'D' IMPACT
DESIGN PRESSURE RATING (GLASS TYPES 'A' & 'A1')
MAXIMUM DESIGN LOAD RATING = + 100.0 PSF
 (FOR SIZES SHOWN ABOVE OR SMALLER) - 100.0 PSF
 SEE SHEET 4 FOR LOCK OPTIONS AND LIMITATIONS.

(XX)

GLASS D.L.O. DIMS.
 D.L.O. HEIGHT = DOOR FRAME HEIGHT - 14.9375"
 D.L.O. WIDTH (X DOORS) = FRAME WIDTH - 12.8125"
 D.L.O. WIDTH (XX DOORS) = (FRAME WIDTH - 21.875")/2

NOTE:
 GLASS CAPACITIES ON THIS SHEET ARE
 BASED ON ASTM E1300-09 (3 SEC. GUSTS)
 AND FLORIDA BUILDING COMMISSION
 DECLARATORY STATEMENT DCA05-DEC-219

Sealed: 07/28/2017

FL #20701

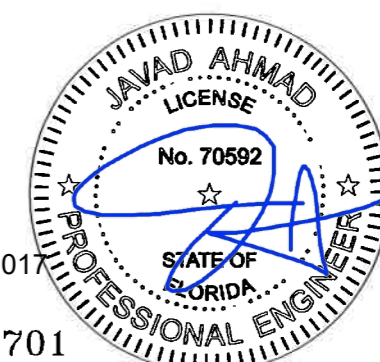

af c
AL-FAROOQ CORPORATION
 ENGINEERS & PRODUCT DEVELOPMENT
 9360 SUNSET DRIVE, SUITE 220
 MIAMI, FLORIDA 33173 (C.A.N. 3538)
 TEL. (305) 264-8100 FAX. (305) 262-6978
 COMP-ANL\W17-43ENV

SERIES ENV-350 INSWING ENTRANCE DOOR (L.M.I.)
ENVIRALUM INDUSTRIES INC.
 5100 N.W. 72 AVENUE BLDG. C
 MIAMI, FL. 33166
 TEL. (305) 752-4411 FAX. (305) 406-3877

no.	date	by	description

date: 04-11-17
 scale: 1/2"=1'-0"
 dr. by: TARIQ
 chk. by:

drawing no.
W17-43
 sheet 2 of 10

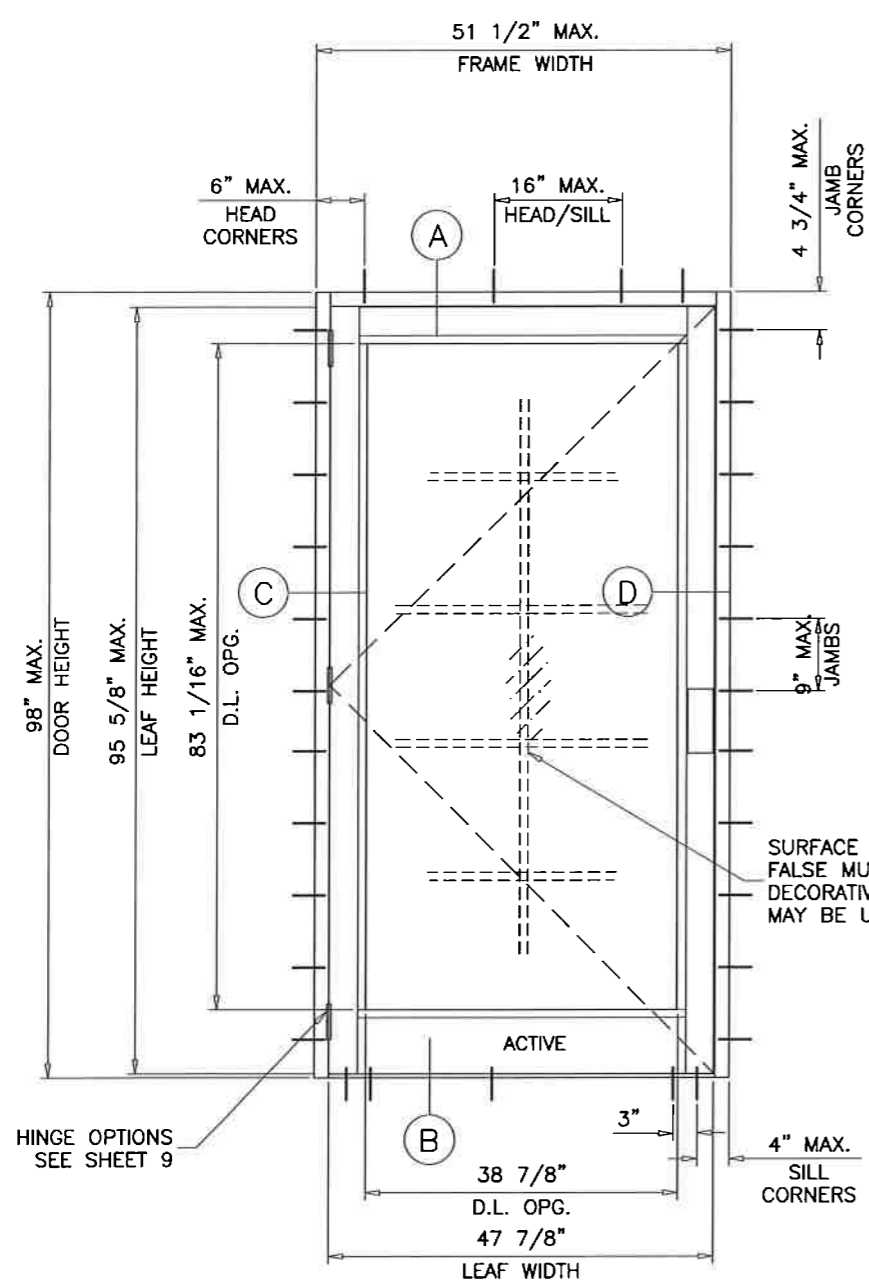

ANCHOR TYPES	NO. OF ANCHORS AT MTG. STILE ENDS	
	1/4" SHIM	3/8" SHIM
A	5	7
B	5	7
C	4	5

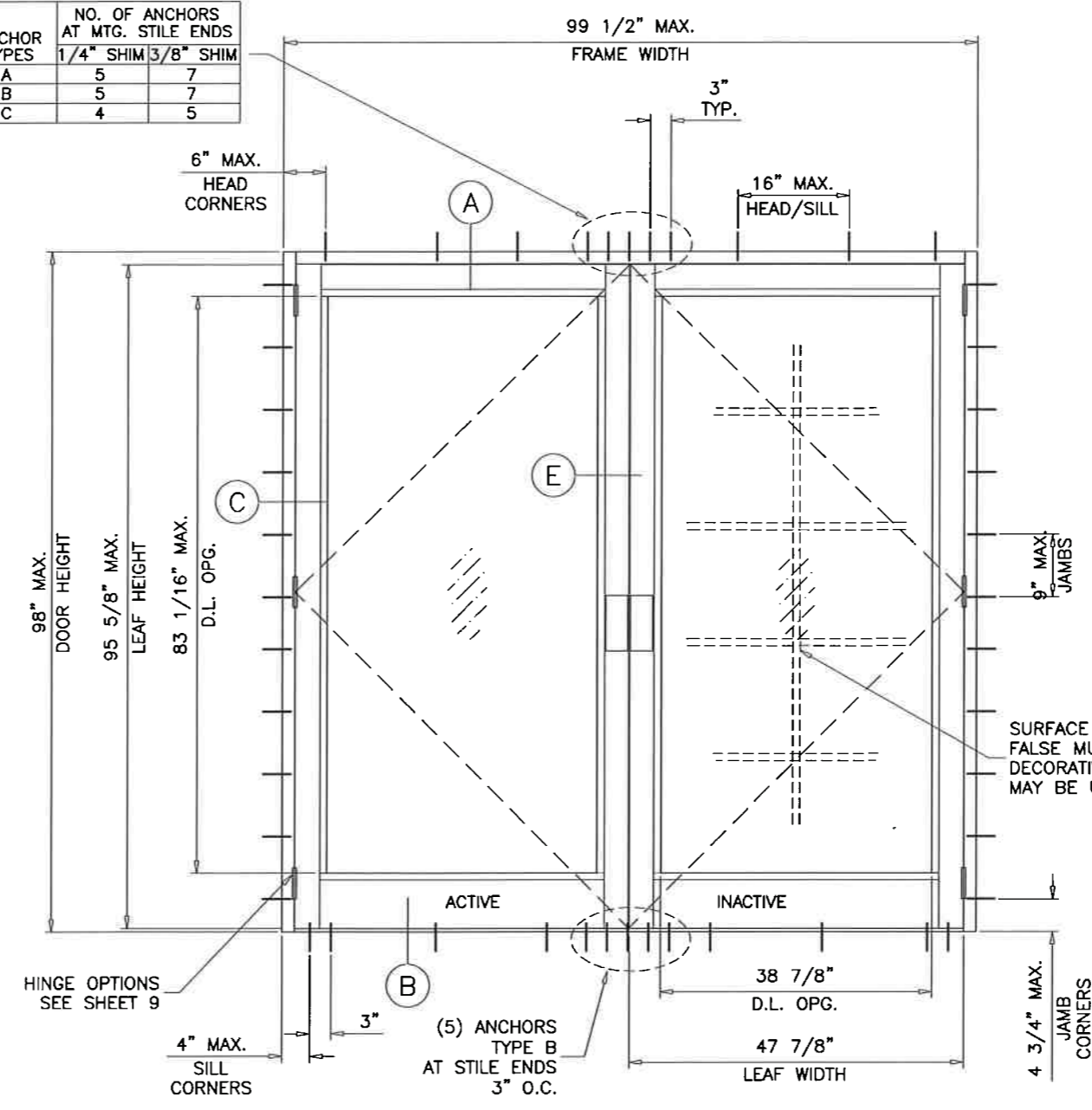

(X)

(XX)

LEVEL 'E' IMPACT
DESIGN PRESSURE RATING (GLASS TYPES 'B' & 'B1')
MAXIMUM DESIGN LOAD RATING = + 100.0 PSF
 (FOR SIZES SHOWN ABOVE OR SMALLER) - 100.0 PSF
 SEE SHEET 4.1 FOR LOCK OPTIONS AND LIMITATIONS.

GLASS D.L.O. DIMS.
 D.L.O. HEIGHT = DOOR FRAME HEIGHT - 14.9375"
 D.L.O. WIDTH (X DOORS) = FRAME WIDTH - 12.8125"
 D.L.O. WIDTH (XX DOORS) = (FRAME WIDTH - 21.875")/2

NOTE:
 GLASS CAPACITIES ON THIS SHEET ARE
 BASED ON ASTM E1300-09 (3 SEC. GUSTS)
 AND FLORIDA BUILDING COMMISSION
 DECLARATORY STATEMENT DCA05-DEC-219

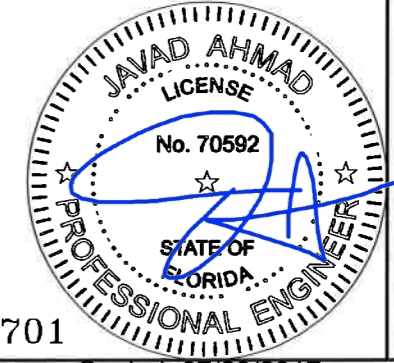

FL #20701

Sealed: 07/28/2017

afc
AL-FAROOQ CORPORATION
 ENGINEERS & PRODUCT DEVELOPMENT
 9360 SUNSET DRIVE, SUITE 220 (C.A.N. 3538)
 MIAMI, FLORIDA 33173 FAX. (305) 262-6978
 TEL. (305) 264-8100

SERIES ENV-350 INSWING ENTRANCE DOOR (L.M.I.)
ENVIRALUM INDUSTRIES INC.
 5100 N.W. 72 AVENUE BLDG. C
 MIAMI, FL. 33166
 TEL. (305) 752-4411 FAX. (305) 406-3877

no	date	by	description

date: 04-11-17	scale: 1/2"=1'-0"	dr. by: TARIQ	chk. by:
----------------	-------------------	---------------	----------

drawing no.
W17-43
 sheet 2.1 of 10

COMP-ANL\W17-43ENV

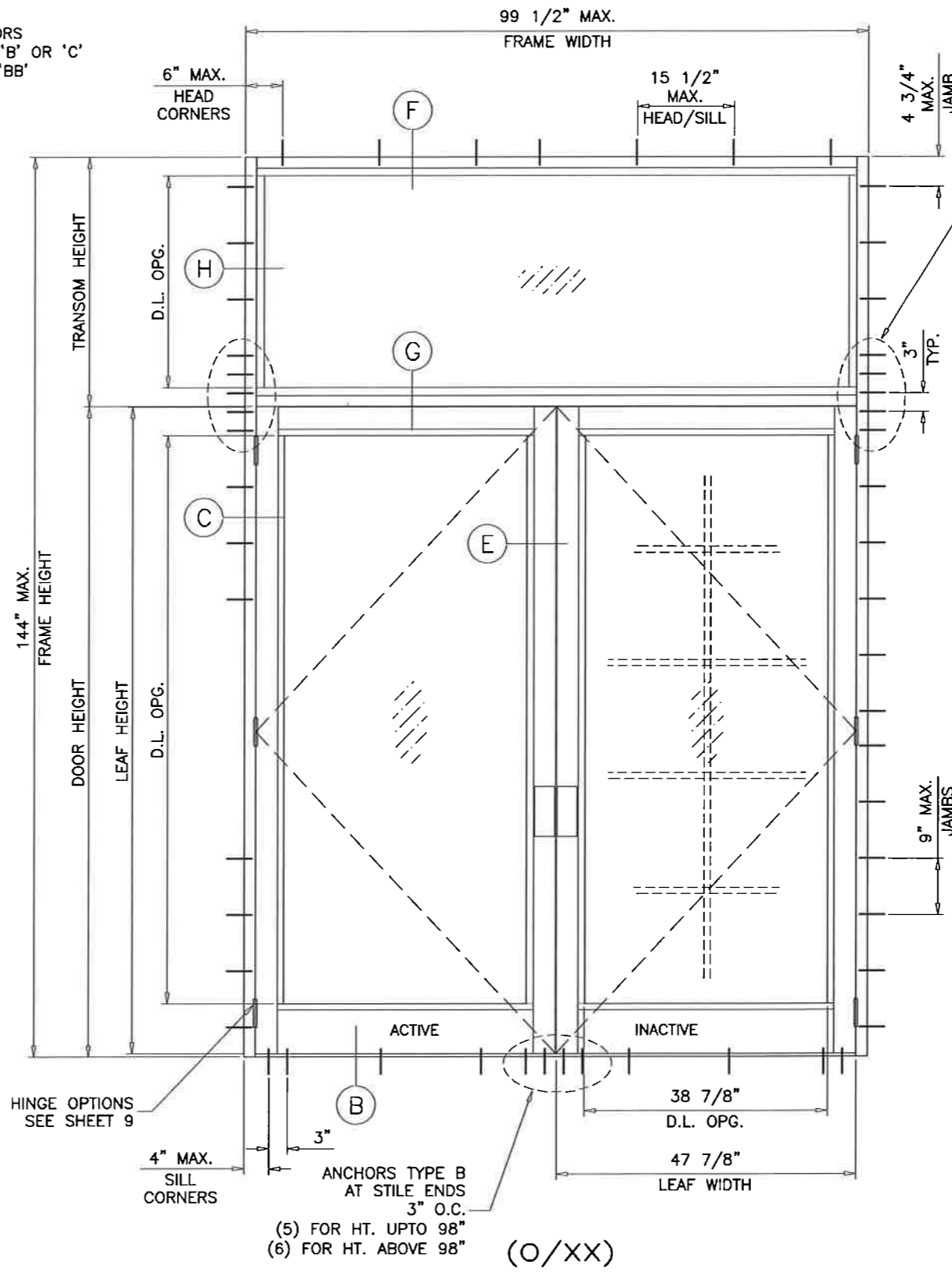
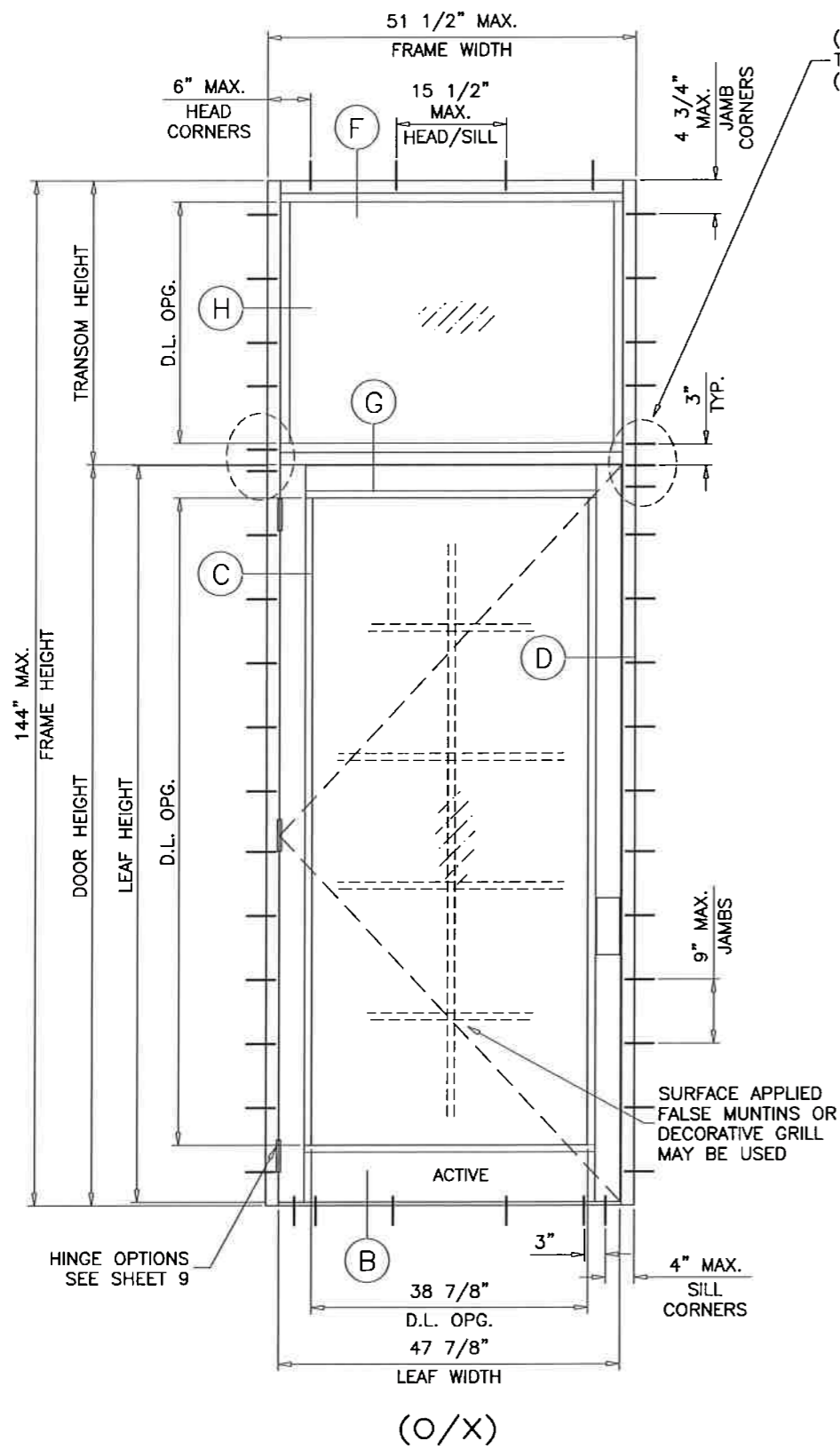

NO. OF ANCHORS AT TRANSOM ENDS		
ANCHOR TYPES	1/4\" SHIM	3/8\" SHIM
A	3	4
B	3	4
BB	5	5
C	3	3

DOORS WITH TRANSOM

SEE SHEET 3.1 FOR TRANSOM (HORIZ. MULLION) DESIGN LOAD CAPACITY,

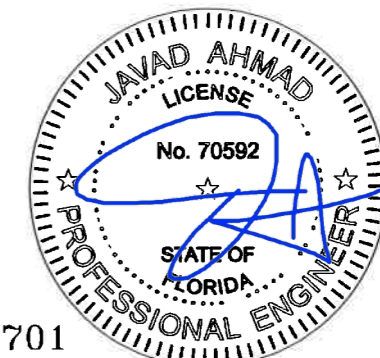

FL #20701

Sealed: 07/28/2017

af c
AL-FAROOQ CORPORATION
 ENGINEERS & PRODUCT DEVELOPMENT
 9360 SUNSET DRIVE, SUITE 220 (C.A.N. 3538)
 MIAMI, FLORIDA 33173 FAX. (305) 262-6978
 TEL. (305) 264-8100 COMP-ANL/W17-43ENV

SERIES ENV-350 INSWING ENTRANCE DOOR (L.M.I.)
ENVIRALUM INDUSTRIES INC.
 5100 N.W. 72 AVENUE BLDG. C
 MIAMI, FL. 33166
 TEL. (305) 752-4411 FAX. (305) 406-3877

revisions:	
no	date by description

date: 04-11-17	scale: 1/2"=1'-0"	dr. by: TARIQ	chk. by:
----------------	-------------------	---------------	----------

drawing no.	W17-43
sheet	3 of 10

LEVEL 'D' & 'E' IMPACT

SINGLE OR DOUBLE DOORS WITH TRANSOM CAPACITY - PSF					
FRAME/TRANSOM WIDTH	DOOR HEIGHT	TRANSOM HEIGHT	WITHOUT REINF.	WITH REINF.	
			EXT.(+) INT.(-)	EXT.(+) INT.(-)	
37-3/4" (X)	75-1/2" (XX)	80"	24"	78.3	100.0
			30"	72.2	100.0
			36"	66.7	100.0
			42"	61.7	95.7
			48"	57.2	87.8
40-3/4" (X)	81-1/2" (XX)	80"	24"	65.7	100.0
			30"	60.3	95.1
			36"	55.4	86.4
			42"	50.9	78.6
43-3/4" (X)	87-1/2" (XX)	80"	24"	55.7	88.7
			30"	50.7	79.9
			36"	46.3	72.0
			42"	42.4	64.8
46-3/4" (X)	93-1/2" (XX)	80"	24"	47.5	75.6
			30"	43.0	67.5
			36"	39.0	60.2
			42"	35.4	53.6
49-3/4" (X)	99-1/2" (XX)	80"	24"	40.8	64.8
			30"	36.7	57.2
			36"	33.0	50.5
			42"	31.9	48.8
37-3/4" (X)	75-1/2" (XX)	84"	24"	75.4	100.0
			30"	69.7	100.0
			36"	64.4	100.0
			42"	59.7	92.7
			48"	55.4	85.1
40-3/4" (X)	81-1/2" (XX)	84"	24"	63.3	100.0
			30"	58.1	91.8
			36"	53.5	83.5
			42"	49.3	76.1
43-3/4" (X)	87-1/2" (XX)	84"	24"	53.6	85.4
			30"	49.0	77.1
			36"	44.8	69.6
			42"	41.0	62.8
46-3/4" (X)	93-1/2" (XX)	84"	24"	45.7	72.8
			30"	41.5	65.1
			36"	37.7	58.2
			42"	34.3	51.9
49-3/4" (X)	99-1/2" (XX)	84"	24"	39.3	62.4
			30"	35.4	55.2
			36"	31.9	48.8

SINGLE OR DOUBLE DOORS WITH TRANSOM CAPACITY - PSF					
FRAME/TRANSOM WIDTH	DOOR HEIGHT	TRANSOM HEIGHT	WITHOUT REINF.	WITH REINF.	
			EXT.(+) INT.(-)	EXT.(+) INT.(-)	
37-3/4" (X)	75-1/2" (XX)	90"	24"	71.5	100.0
			30"	66.2	100.0
			36"	61.4	96.2
			42"	57.0	88.5
			48"	53.0	81.4
40-3/4" (X)	81-1/2" (XX)	90"	24"	60.0	95.6
			30"	55.2	87.2
			36"	51.0	79.6
			42"	47.1	72.6
43-3/4" (X)	87-1/2" (XX)	90"	24"	50.8	80.9
			30"	46.5	73.2
			36"	42.7	66.3
			42"	39.2	59.9
46-3/4" (X)	93-1/2" (XX)	90"	24"	43.3	69.0
			30"	39.5	61.9
			36"	35.9	55.4
49-3/4" (X)	99-1/2" (XX)	90"	24"	37.2	59.1
			30"	33.6	52.5
			36"	30.0	45.8
37-3/4" (X)	75-1/2" (XX)	96"	24"	67.9	100.0
			30"	63.0	99.7
			36"	58.6	91.8
			42"	54.5	84.6
			48"	50.8	78.0
40-3/4" (X)	81-1/2" (XX)	96"	24"	57.0	90.9
			30"	52.6	83.1
			36"	48.7	75.9
			42"	45.0	69.5
43-3/4" (X)	87-1/2" (XX)	96"	24"	48.2	76.9
			30"	44.3	69.7
			36"	40.7	63.2
			42"	37.6	58.9
46-3/4" (X)	93-1/2" (XX)	96"	24"	41.2	65.5
			30"	37.6	58.9
			36"	34.0	52.2
49-3/4" (X)	99-1/2" (XX)	96"	24"	35.4	56.1
			30"	31.9	48.8

SINGLE OR DOUBLE DOORS WITH TRANSOM CAPACITY - PSF					
FRAME/TRANSOM WIDTH	DOOR HEIGHT	TRANSOM HEIGHT	WITHOUT REINF.	WITH REINF.	
			EXT.(+) INT.(-)	EXT.(+) INT.(-)	
37-3/4" (X)	75-1/2" (XX)	102"	24"	64.7	100.0
			30"	60.2	95.1
			36"	56.0	87.8
			42"	52.3	81.1
			48"	48.6	74.4
40-3/4" (X)	81-1/2" (XX)	102"	24"	54.2	86.5
			30"	50.2	79.8
			36"	46.5	72.6
			42"	43.2	66.6
43-3/4" (X)	87-1/2" (XX)	102"	24"	45.9	73.2
			30"	42.3	66.6
46-3/4" (X)	93-1/2" (XX)	102"	24"	39.2	62.4
			30"	35.6	55.7
37-3/4" (X)	75-1/2" (XX)	108"	24"	61.7	98.5
			30"	57.5	91.0
			36"	53.7	84.1
			42"	50.0	77.2
40-3/4" (X)	81-1/2" (XX)	108"	24"	51.8	82.6
			30"	48.0	75.8
			36"	44.6	69.6
43-3/4" (X)	87-1/2" (XX)	108"	24"	43.9	69.9
			30"	40.3	63.1

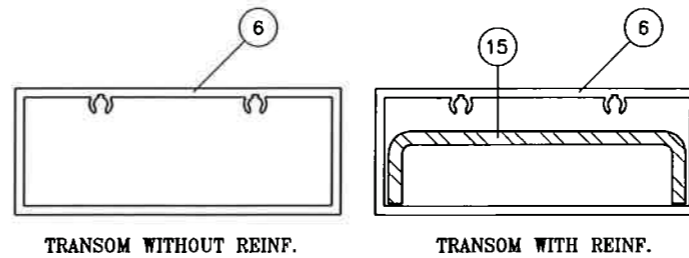

NOTE:
GLASS CAPACITIES ON THIS SHEET ARE
BASED ON ASTM E1300-09 (3 SEC. GUSTS)
AND FLORIDA BUILDING COMMISSION
DECLARATORY STATEMENT DCA05-DEC-219

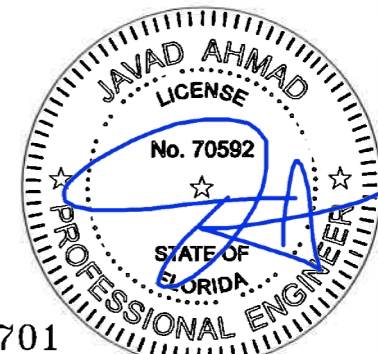

FL #20701

Sealed: 07/28/2017

af c
AL-FAROOQ CORPORATION
ENGINEERS & PRODUCT DEVELOPMENT
9360 SUNSET DRIVE, SUITE 220
MIAMI, FLORIDA 33173 (C.A.N. 3538)
TEL. (305) 264-8100 FAX. (305) 262-6978
COMP-ANL\W17-43ENV

SERIES ENW-350 INSWING ENTRANCE DOOR (L.M.I.)
ENVRALUM INDUSTRIES INC.
5100 N.W. 72 AVENUE BLDG. C
MIAMI, FL. 33166
TEL. (305) 752-4411 FAX. (305) 406-3877

revisions:	no	date	by	description

date: 04-11-17
scale: 1/2"=1'-0"
dr. by: TARIQ
chk. by:

drawing no.
W17-43
sheet 3.1 of 10

LOCK OPTIONS: LEVEL 'D' IMPACT

STD. 3 POINT LOCK (LEVEL 'D' IMPACT ONLY)
 MAX. FRAME HEIGHT = 120 IN.
 MAX. LEAF WIDTH = 48 IN.
 MAX. DESIGN LOAD = 100 PSF

ACTIVE LEAF:

3 POINT LOCK SYSTEM BY 'INTERLOCK' AT 39" FROM BOTTOM
 HANDLE ACTIVATES DEAD BOLT AND SHOOT BOLTS ENGAGING AT HEAD AND SILL
 KEY OPERATED ON EXTERIOR AND THUMB TURN ON INTERIOR
 FASTENED TO ACTIVE LEAF LOCK STILE WITH
 (2) #8-32 X 2" OH MS

INACTIVE LEAF:

2 POINT LOCK SYSTEM BY 'INTERLOCK' AT 39" FROM BOTTOM
 HANDLE ACTIVATES SHOOT BOLTS ENGAGING AT HEAD AND SILL
 FASTENED TO INACTIVE LEAF LOCK STILE WITH
 (2) #8-32 X 2" OH MS

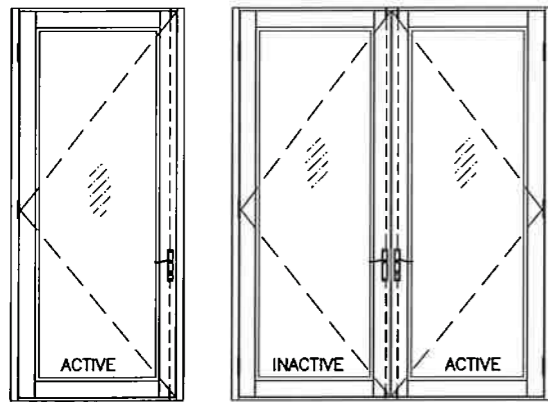

STD. 3 POINT LOCK (LEVEL 'D' IMPACT ONLY)
 MAX. FRAME HEIGHT = 120 IN.
 MAX. LEAF WIDTH = 48 IN.
 MAX. DESIGN LOAD = 100 PSF

ACTIVE LEAF:

THREE POINT LOCK SYSTEM SERIES 2222 BY 'REGENT HARDWARE'
 KEY OPERATED FROM EXTERIOR AND THUMB TURN ON INTERIOR WITH CONCEALED FLUSH BOLTS AT TOP & BOTTOM OF LOCK STILE
 LOCATED AT 34" FROM BOTTOM OF LEAF

INACTIVE LEAF:

MANUALLY OPERATED TWO POINT LOCK SYSTEM BY 'REGENT HARDWARE' WITH CONCEALED FLUSH BOLTS AT TOP & BOTTOM OF LOCK STILE
 FASTENED WITH
 (2) #8-32 X 1/4" PH MACHINE SCREWS

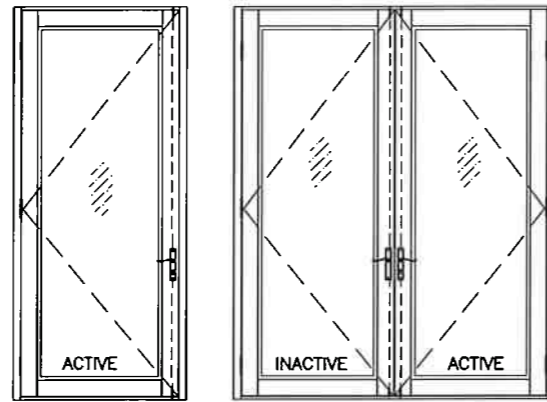

STD. 3 POINT LOCK (LEVEL 'D' IMPACT ONLY)
 MAX. FRAME HEIGHT = 120 IN.
 MAX. LEAF WIDTH = 48 IN.
 MAX. DESIGN LOAD = 100 PSF

ACTIVE LEAF:

KEY OPERATED THREE POINT LOCK SYSTEM BY 'ADAMS RITE' WITH CONCEALED FLUSH BOLTS AT TOP & BOTTOM OF LOCK STILE AND A THUMB TURN ON THE INTERIOR, LOCATED AT 40" FROM BOTTOM OF PANEL
 FASTENED WITH
 (2) #12-24 X 1/2" FH MACHINE SCREWS

INACTIVE LEAF:

MANUALLY OPERATED TWO POINT LOCK SYSTEM BY 'ADAMS RITE' WITH CONCEALED FLUSH BOLTS AT TOP & BOTTOM OF LOCK STILE
 FASTENED WITH
 (2) #8-32 X 1/4" PH MACHINE SCREWS

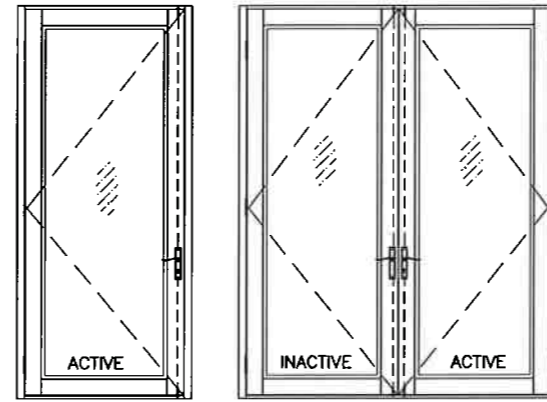

FRAME HEIGHTS DOES INCLUDE OPTIONAL TRANSOM

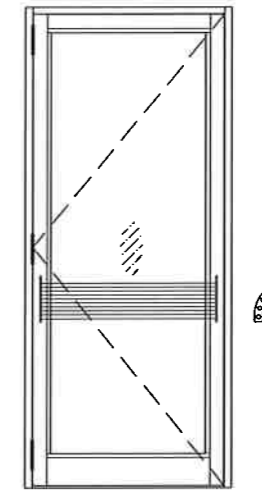

PANIC DEVICE GUARD

(5) 1" DIA. ROUND ALUM BARS SPACED 1" APART
 SCREWED TO A 3/8" THICK FLAT BAR FASTENED TO DOOR LEAF WITH
 (4) 1/4-20 X 3/4" SMS

GUARD TO BE INSTALLED OVER PANIC DEVICE DURING PERIODS OF HURRICANE WARNING.

PANIC EXIT DEVICE (LEVEL 'D' IMPACT ONLY)
 MAX. FRAME HEIGHT = 98 IN.
 MAX. LEAF WIDTH = 48 IN.
 MAX. DESIGN LOAD = 75 PSF

ACTIVE & INACTIVE LEAF:

CONCEALED VERTICAL ROD PANIC EXIT DEVICE # 5770 BY 'REGENT HARDWARE' LOCATED AT 40" FROM SILL AT EACH LEAF.
 FASTENED WITH
 (1) #10 X 3/8" FH SELF DRILLING SCREW AT ONE END AND
 (2) #10 X 1/2" FH SELF DRILLING SCREWS AT OTHER END

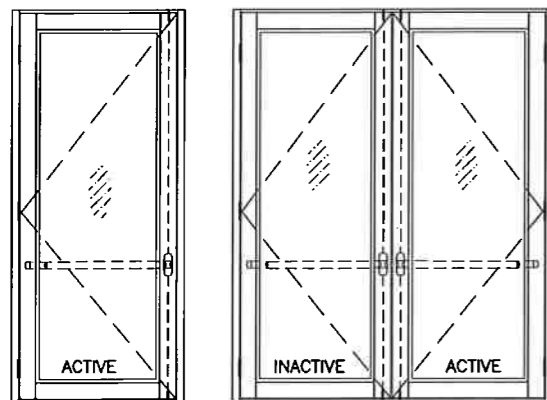

PANIC EXIT DEVICE (LEVEL 'D' IMPACT ONLY)
 MAX. FRAME HEIGHT = 120 IN.
 MAX. LEAF WIDTH = 48 IN.
 MAX. DESIGN LOAD = 100 PSF

ACTIVE & INACTIVE LEAF:

CONCEALED VERTICAL ROD PANIC EXIT DEVICE # G86 BY 'ADAMS RITE' LOCATED AT 40" FROM SILL AT EACH LEAF.
 FASTENED WITH
 (2) #10-32 X 3/4" FH MACHINE SCREWS AT ONE END AND
 (2) #10-24 X 1/2" FH MACHINE SCREWS AT OTHER END

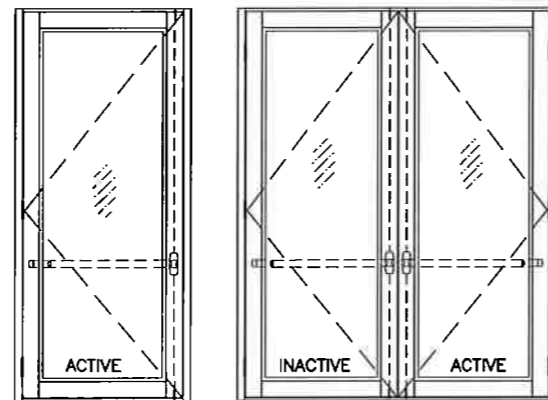

PANIC EXIT DEVICE (LEVEL 'D' IMPACT ONLY)
 MAX. FRAME HEIGHT = 120 IN.
 MAX. LEAF WIDTH = 48 IN.
 MAX. DESIGN LOAD = 100 PSF

ACTIVE & INACTIVE LEAF:

CONCEALED VERTICAL ROD PANIC EXIT DEVICE PRECISION 2800 BY 'STANLEY' LOCATED AT 40" FROM SILL AT EACH LEAF.
 FASTENED WITH
 (2) #10-32 X 3/4" FH MACHINE SCREWS AT ONE END AND
 (2) #10-24 X 1/2" FH MACHINE SCREWS AT OTHER END

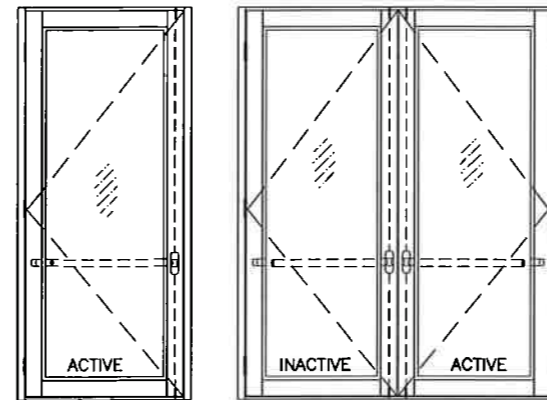

af c
AL-FAROOQ CORPORATION
 ENGINEERS & PRODUCT DEVELOPMENT
 9360 SUNSET DRIVE, SUITE 220 (C.A.N. 3538)
 MIAMI, FLORIDA 33173
 TEL. (305) 264-8100 FAX. (305) 262-6978
 COMP-ANL\W17-43ENV

SERIES ENV-350 INSWING ENTRANCE DOOR (L.M.I.)
ENVRALUM INDUSTRIES INC.
 5100 N.W. 72 AVENUE BLDG. C
 MIAMI, FL. 33166
 TEL. (305) 752-4411 FAX. (305) 406-3877

no	date	by	description

date: 04-11-17
 scale: 3/8" = 1"
 dr. by: TARIQ
 chk. by:

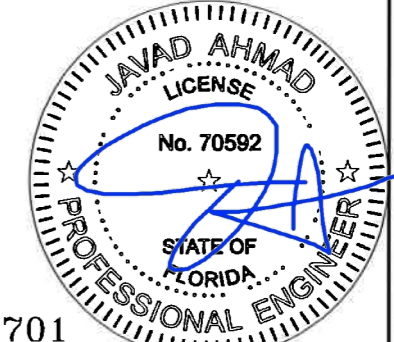

FL #20701

drawing no.
W17-43
 sheet 4 of 10

LOCK OPTIONS: LEVEL 'E' IMPACT

STD. 3 POINT LOCK (LEVEL 'E' IMPACT)
 MAX. FRAME HEIGHT = 98 IN.
 MAX. LEAF WIDTH = 48 IN.
 MAX. DESIGN LOAD = 100 PSF

ACTIVE LEAF:

THREE POINT LOCK SYSTEM SERIES 2222 BY 'REGENT HARDWARE'
 KEY OPERATED FROM EXTERIOR AND THUMB TURN ON INTERIOR WITH CONCEALED FLUSH BOLTS AT TOP & BOTTOM OF LOCK STILE LOCATED AT 40" FROM BOTTOM OF LEAF

INACTIVE LEAF:

MANUALLY OPERATED TWO POINT LOCK SYSTEM BY 'REGENT HARDWARE' WITH CONCEALED FLUSH BOLTS AT TOP & BOTTOM OF LOCK STILE FASTENED WITH
 (2) #8-32 X 1/4" PH MACHINE SCREWS

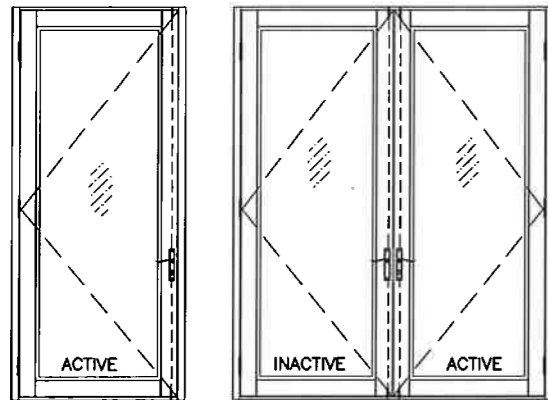

STD. 3 POINT LOCK (LEVEL 'E' IMPACT)
 MAX. FRAME HEIGHT = 98 IN.
 MAX. LEAF WIDTH = 48 IN.
 MAX. DESIGN LOAD = 100 PSF

ACTIVE LEAF:

KEY OPERATED THREE POINT LOCK SYSTEM BY 'ADAMS RITE' WITH CONCEALED FLUSH BOLTS AT TOP & BOTTOM OF LOCK STILE AND A THUMB TURN ON THE INTERIOR, LOCATED AT 40" FROM BOTTOM OF PANEL FASTENED WITH
 (2) #12-24 X 1/2" FH MACHINE SCREWS

INACTIVE LEAF:

MANUALLY OPERATED TWO POINT LOCK SYSTEM BY 'ADAMS RITE' WITH CONCEALED FLUSH BOLTS AT TOP & BOTTOM OF LOCK STILE FASTENED WITH
 (2) #8-32 X 1/4" PH MACHINE SCREWS

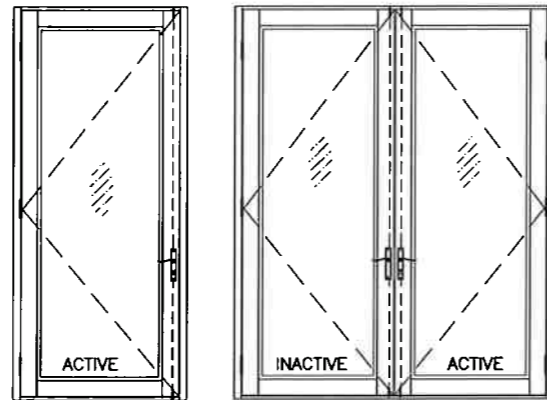

PANIC EXIT DEVICE (LEVEL 'E' IMPACT)
 MAX. FRAME HEIGHT = 98 IN.
 MAX. LEAF WIDTH = 48 IN.
 MAX. DESIGN LOAD = 100 PSF

ACTIVE & INACTIVE LEAF:

CONCEALED VERTICAL ROD PANIC EXIT DEVICE PRECISION 2800 BY 'STANLEY' LOCATED AT 40" FROM SILL AT EACH LEAF. FASTENED WITH
 (2) #10-32 X 3/4" FH MACHINE SCREWS AT ONE END AND
 (2) #10-24 X 1/2" FH MACHINE SCREWS AT OTHER END

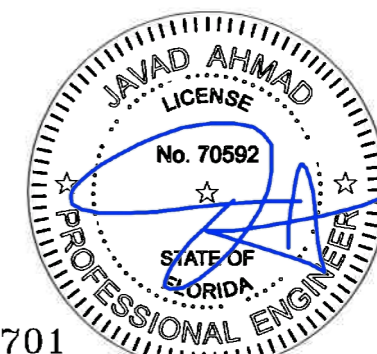
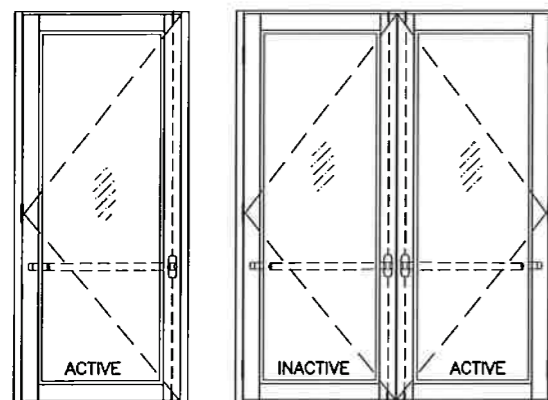

FL #20701

Sealed: 07/28/2017

afc
AL-FAROOQ CORPORATION
 ENGINEERS & PRODUCT DEVELOPMENT
 9360 SUNSET DRIVE, SUITE 220 (C.A.N. 3538)
 MIAMI, FLORIDA 33173 FAX. (305) 262-6978
 TEL. (305) 264-8100 COMP-ANL\W17-43ENV

SERIES ENV-350 INSWING ENTRANCE DOOR (L.M.I.)
ENVIRALUM INDUSTRIES INC.
 5100 N.W. 72 AVENUE BLDG. C
 MIAMI, FL. 33166
 TEL. (305) 752-4411 FAX. (305) 406-3877

revisions:	no	date	by	description

date: 04-11-17
 scale: 3/8" = 1"
 dr. by: TARIQ
 chk. by:

drawing no.
W17-43

sheet 4.1 of 10

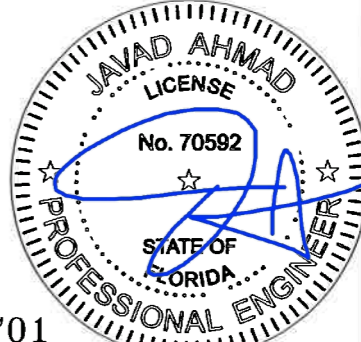
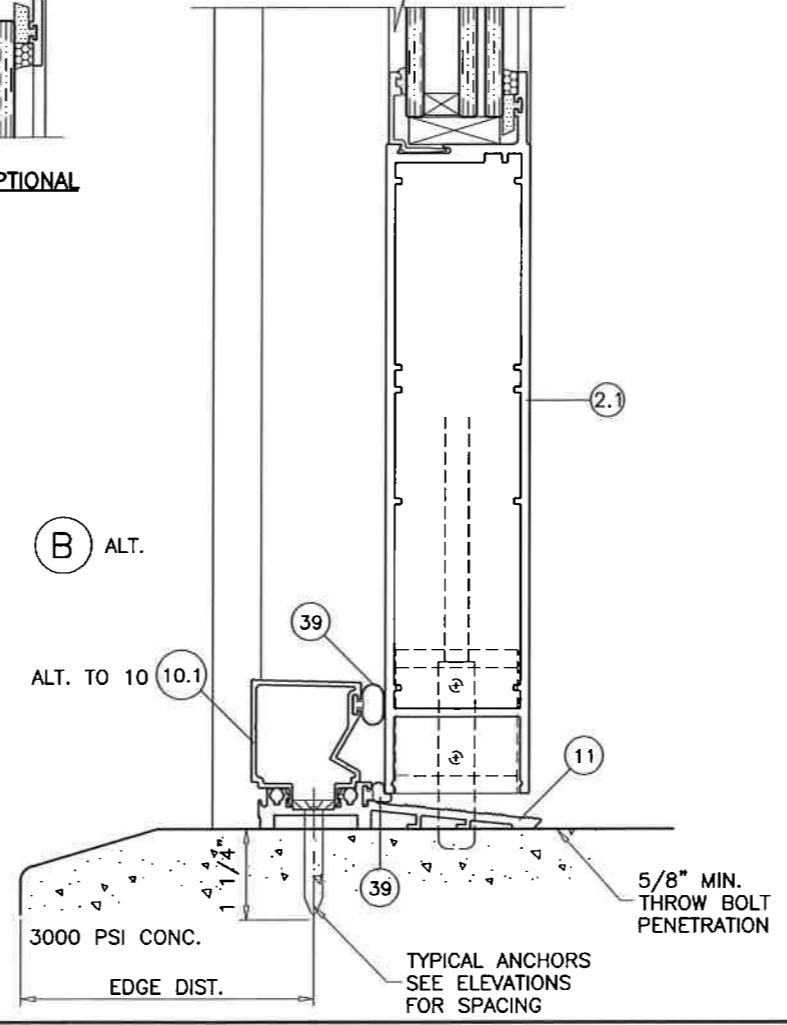
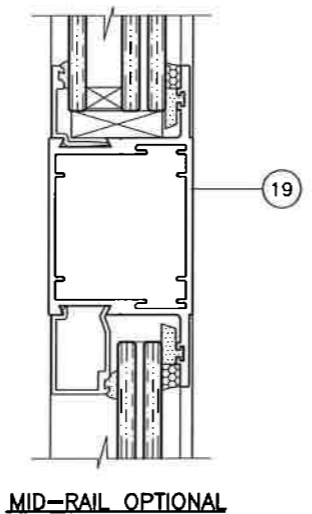
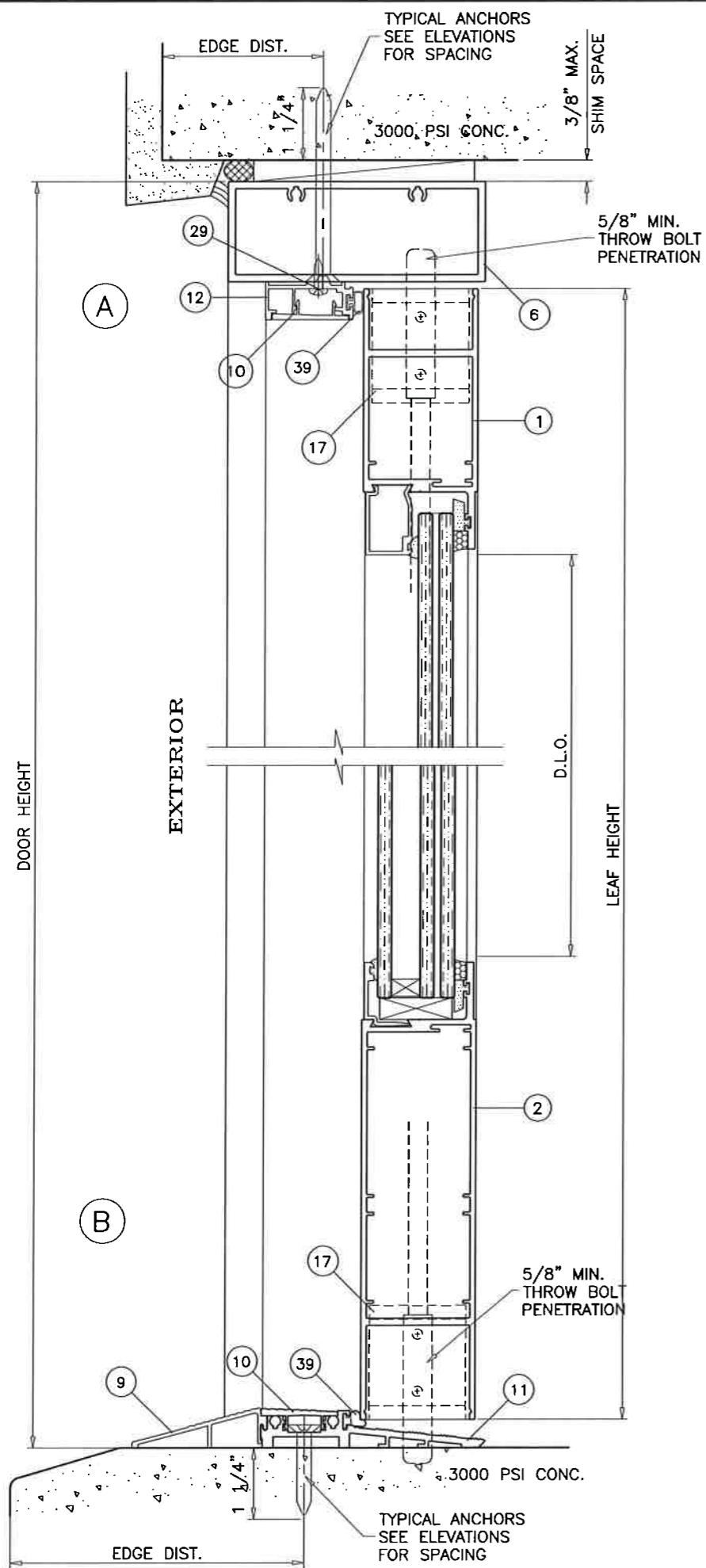

FL #20701

Sealed: 07/28/2017

afc
AL-FAROOQ CORPORATION
 ENGINEERS & PRODUCT DEVELOPMENT
 9360 SUNSET DRIVE, SUITE 220
 MIAMI, FLORIDA 33173 (C.A.N. 3538)
 TEL. (305) 264-8100 FAX. (305) 262-6978
 COMP-ANL\W17-43ENV

SERIES ENV-350 INSWING ENTRANCE DOOR (L.M.I.)
ENVRALUM INDUSTRIES INC.
 5100 N.W. 72 AVENUE BLDG. C
 MIAMI, FL. 33166
 TEL. (305) 752-4411 FAX. (305) 406-3877

revisions:	
no	date by description

date: 04-11-17
 scale: 3/8" = 1"
 dr. by: TARIQ
 chk. by:

drawing no.
W17-43
 sheet 5 of 10

WOOD BUCKS AND METAL STRUCTURE NOT BY ENVIRALUM MUST SUSTAIN LOADS IMPOSED BY GLAZING SYSTEM AND TRANSFER THEM TO THE BUILDING STRUCTURE.

TYPICAL ANCHORS: SEE ELEV. FOR SPACING

TYPE 'A' - 5/16" DIA ULTRACON BY 'ELCO' (Fu=177 KSI, Fy=155 KSI)
 INTO WOOD STRUCTURES
 2" MIN. PENETRATION INTO WOOD (HEAD/SILL/JAMBS)
 THRU 1BY OR 2BY BUCKS INTO CONC. OR MASONRY
 1-3/4" MIN. EMBED INTO CONCRETE (HEAD/SILL/JAMBS)
 1-3/4" MIN. EMBED INTO FILLED BLOCKS (JAMBS)
 DIRECTLY INTO MASONRY
 1-3/4" MIN. EMBED INTO FILLED BLOCKS (JAMBS)

ANCHOR EDGE DISTANCES

INTO CONCRETE AND MASONRY = 2-1/2" MIN.
 INTO WOOD STRUCTURE = 1-1/4" MIN.

ANCHOR CL TO CL DISTANCE

INTO CONCRETE = 3" MIN.
 INTO FILLED BLOCKS = 4" MIN.

TYPE 'B' - 5/16" DIA ULTRACON BY 'ELCO' (Fu=177 KSI, Fy=155 KSI)
 DIRECTLY INTO CONCRETE
 1-3/4" MIN. EMBED INTO CONCRETE (HEAD/SILL/JAMBS)

TYPE 'BB' - 5/16" DIA ULTRACON BY 'ELCO' (Fu=177 KSI, Fy=155 KSI)
 DIRECTLY INTO GROUT FILLED BLOCKS
 1-3/4" MIN. EMBED INTO FILLED BLOCKS (JAMBS)

ANCHOR EDGE DISTANCES

INTO CONCRETE = 2-3/16" MIN.

ANCHOR CL TO CL DISTANCE

INTO CONCRETE = 3" MIN.
 INTO FILLED BLOCKS = 5" MIN.

TYPE 'C' - 5/16" DIA. TEKS OR SELF DRILLING SCREWS (GRADE 5 CRS)
 INTO MIAMI-DADE COUNTY APPROVED MULLIONS
 OR
 INTO METAL STRUCTURES
 (3) THREADS MIN. PENETRATION BEYOND METAL SUBSTRATE
 ALUMINUM: 1/8" THK. MIN. (6063-T5 MIN.)
 STEEL: 1/8" THK. MIN. (Fy = 36 KSI MIN.)
 (STEEL IN CONTACT WITH ALUMINUM TO BE PLATED OR PAINTED)

ANCHOR EDGE DISTANCES

INTO METAL STRUCTURE = 1/2" MIN.

WOOD AT HEAD, SILL OR JAMBS SG = 0.55 MIN.
 CONCRETE AT HEAD, SILL OR JAMBS f'c = 3000 PSI MIN.
 C-90 GROUT FILLED BLOCK AT JAMBS f'm = 2000 PSI MIN.

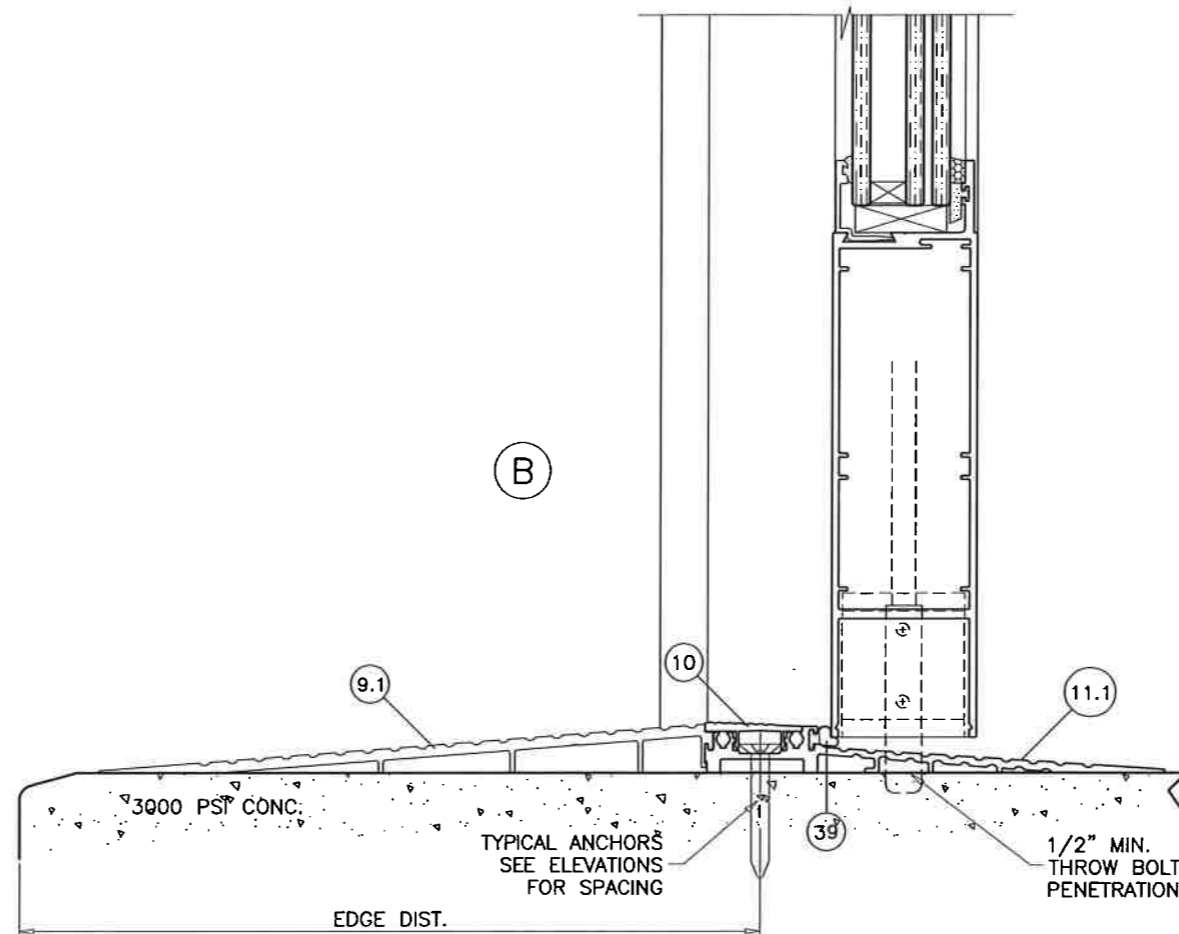
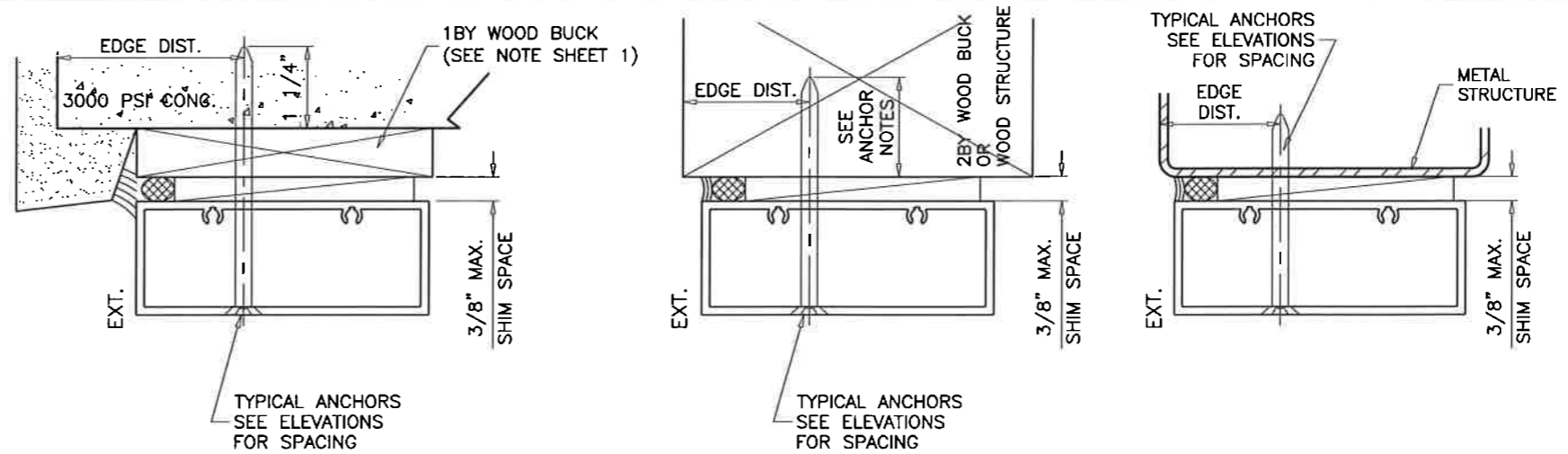

ADA COMPLIANT THRESHOLD

FL #20701

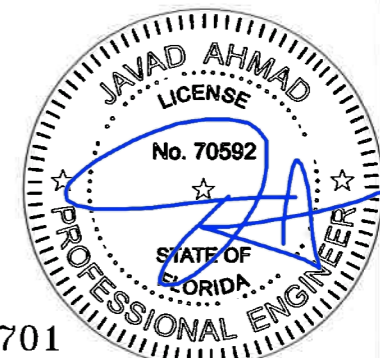

af c
AL-FAROOQ CORPORATION
 ENGINEERS & PRODUCT DEVELOPMENT
 9360 SUNSET DRIVE, SUITE 220 (C.A.N. 3538)
 MIAMI, FLORIDA 33173 FAX. (305) 262-6978
 TEL. (305) 264-8100

SERIES ENV-350 INSWING ENTRANCE DOOR (L.M.I.)
ENVIRALUM INDUSTRIES INC.
 5100 N.W. 72 AVENUE BLDG. C
 MIAMI, FL. 33166
 TEL. (305) 752-4411 FAX. (305) 406-3877

revisions:	
no	date by description

date: 04-11-17
 scale: 3/8" = 1"
 dr. by: TARIQ
 chk. by:

drawing no.
W17-43
 sheet 5.1 of 10

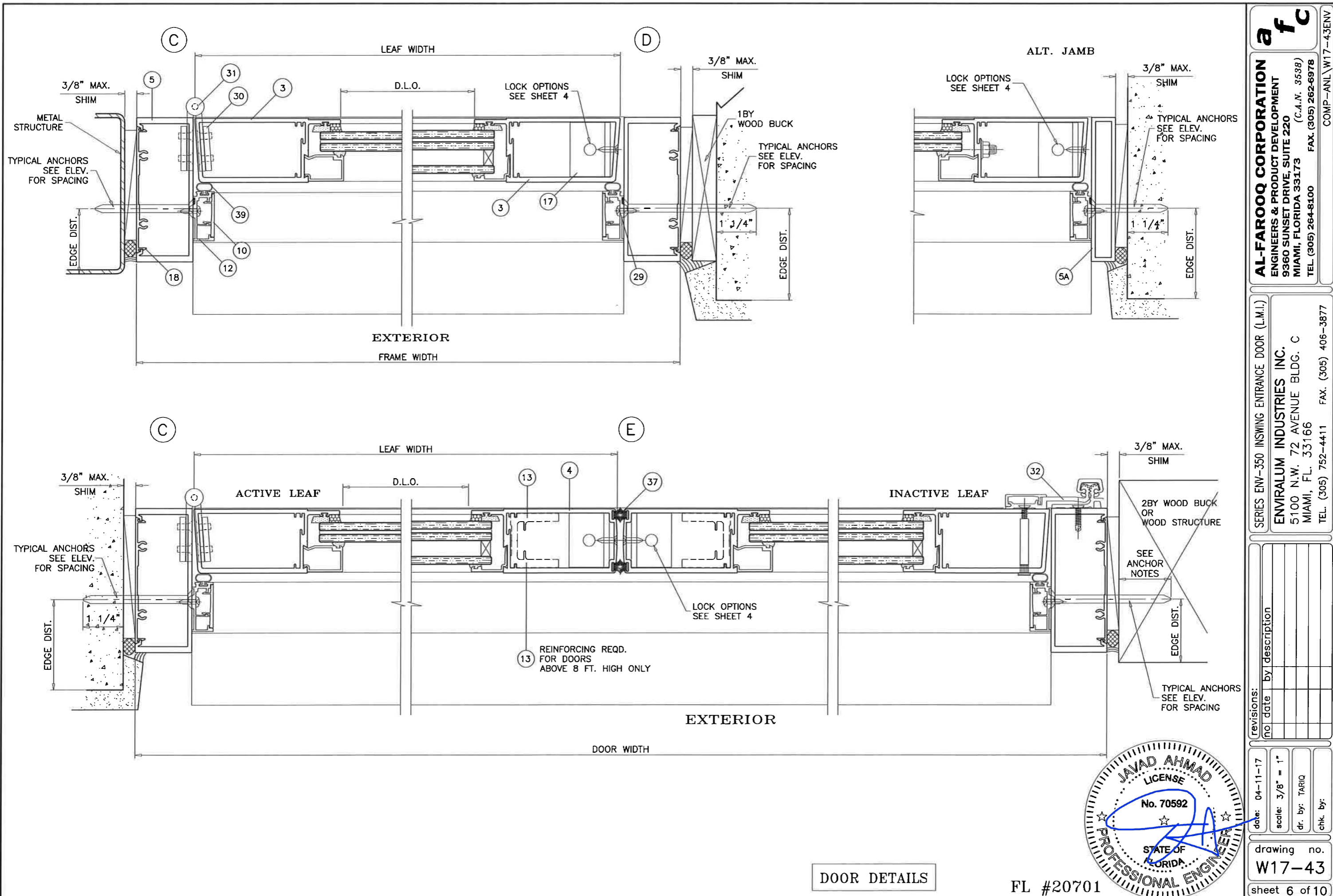

af c
AL-FAROOQ CORPORATION
 ENGINEERS & PRODUCT DEVELOPMENT
 9360 SUNSET DRIVE, SUITE 220 (C.A.N. 3538)
 MIAMI, FLORIDA 33173
 TEL. (305) 264-8100 FAX. (305) 262-6978
 COMP-ANL\W17-43ENV

SERIES ENV-350 INSWING ENTRANCE DOOR (L.M.I.)
ENVRALUM INDUSTRIES INC.
 5100 N.W. 72 AVENUE BLDG. C
 MIAMI, FL. 33166
 TEL. (305) 752-4411 FAX. (305) 406-3877

no	date	by	description

date: 04-11-17
 scale: 3/8" = 1"
 dr. by: TARIQ
 chk. by:

drawing no.
W17-43
 sheet 6 of 10

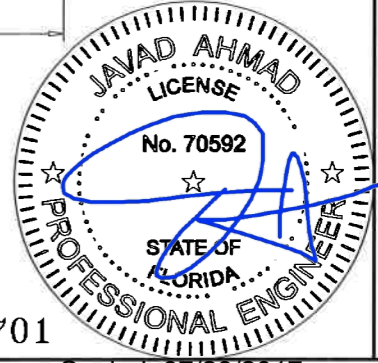

DOOR DETAILS

FL #20701

Sealed: 07/28/2017

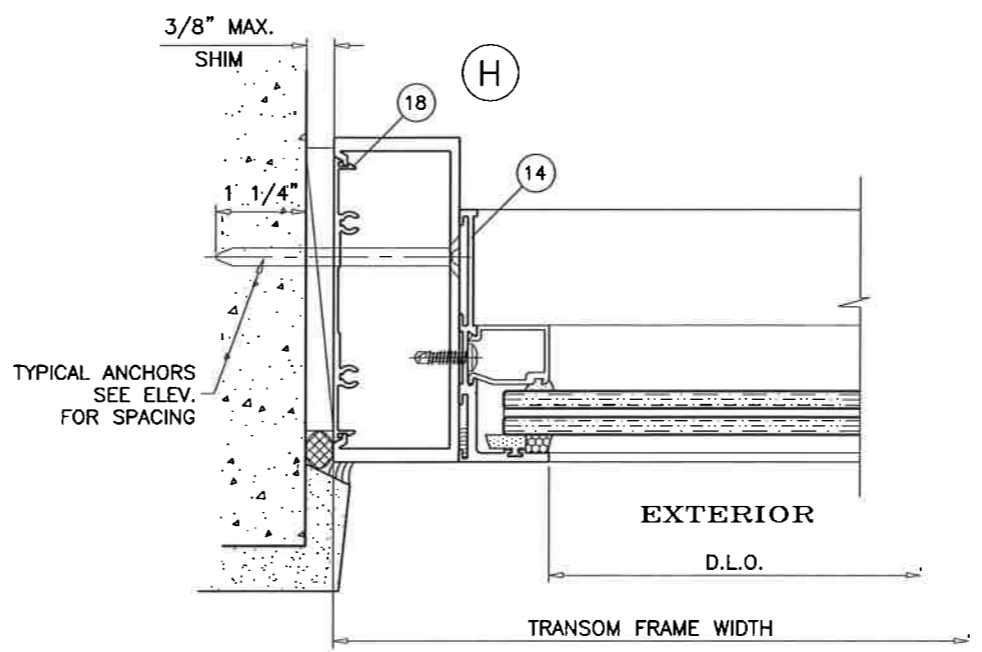
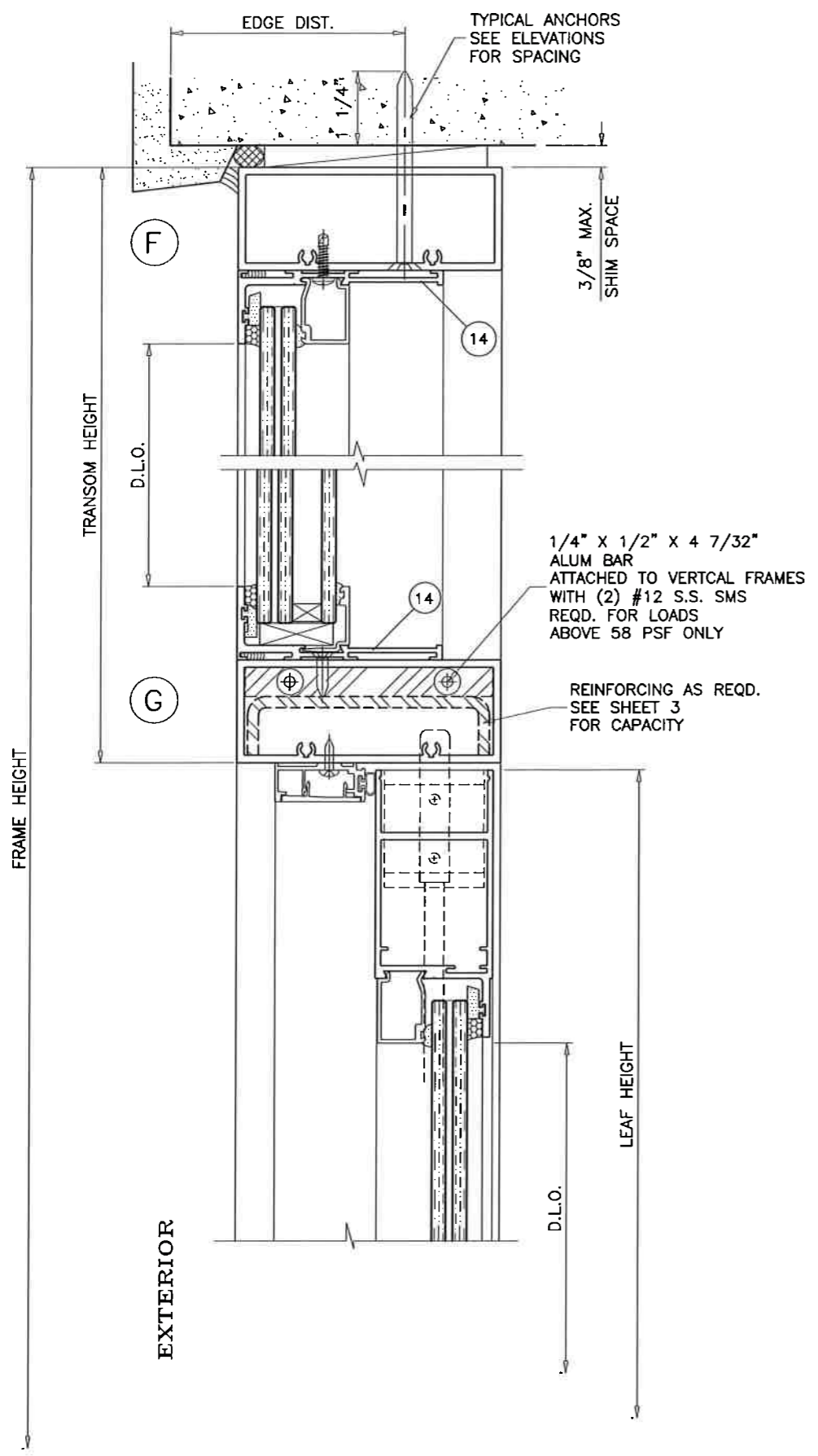

TRANSOM DETAILS

FL #20701

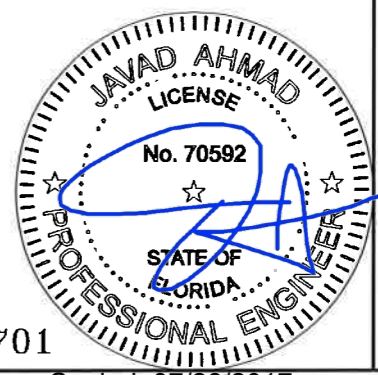

Sealed: 07/28/2017

af c
AL-FAROOQ CORPORATION
 ENGINEERS & PRODUCT DEVELOPMENT
 9360 SUNSET DRIVE, SUITE 220
 MIAMI, FLORIDA 33173 (C.A.N. 3538)
 TEL. (305) 264-8100 FAX. (305) 262-6978
 COMP-ANL\W17-43ENV

SERIES ENV-350 INSWING ENTRANCE DOOR (L.M.I.)
ENVRALUM INDUSTRIES INC.
 5100 N.W. 72 AVENUE BLDG. C
 MIAMI, FL. 33166
 TEL. (305) 752-4411 FAX. (305) 406-3877

no	date	by	description

date: 04-11-17	scale: 3/8" = 1"
dr. by: TARIQ	chk. by:

drawing no.
W17-43
 sheet 7 of 10

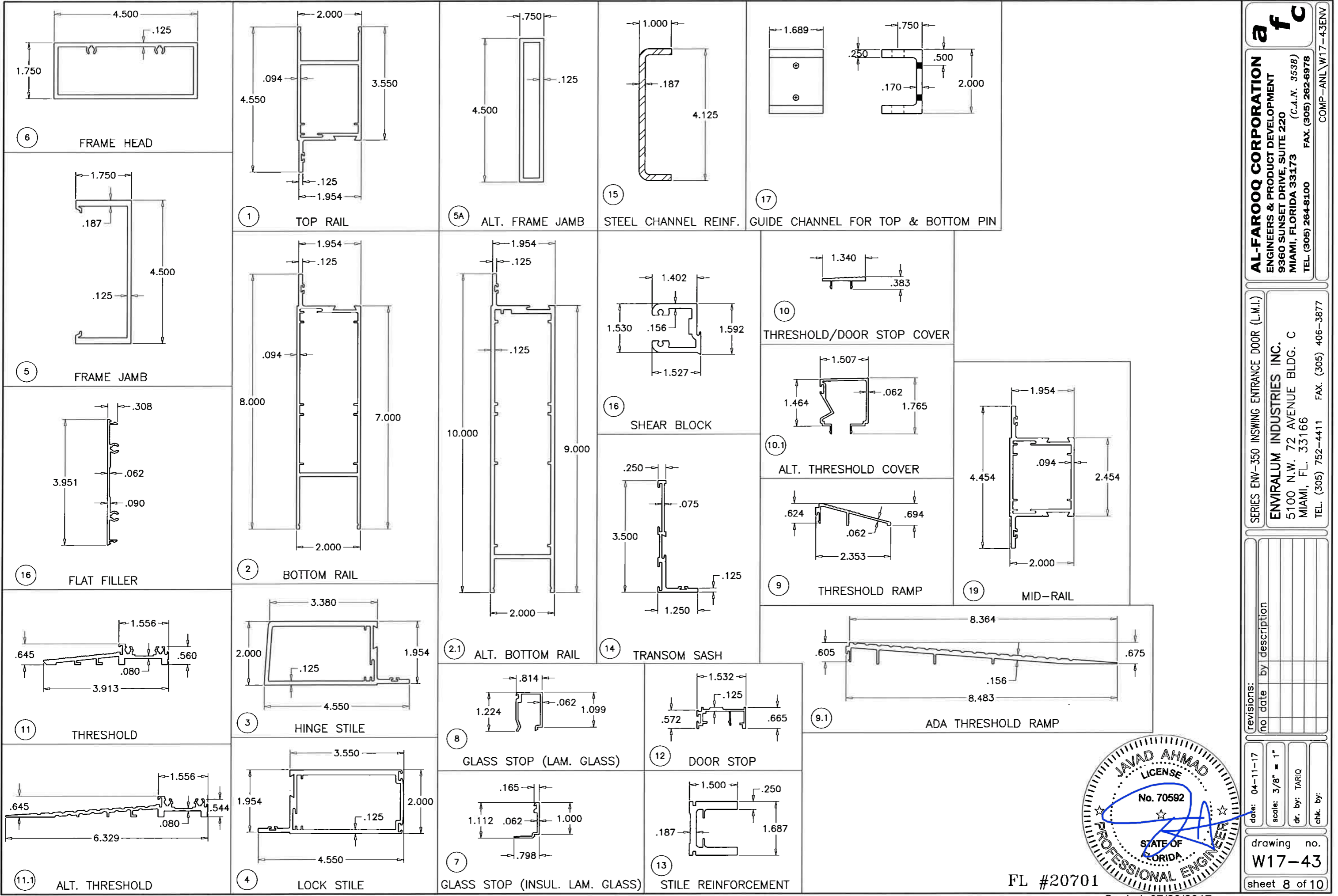

af c
AL-FAROOQ CORPORATION
 ENGINEERS & PRODUCT DEVELOPMENT
 9360 SUNSET DRIVE, SUITE 220 (C.A.N. 3538)
 MIAMI, FLORIDA 33173 TEL. (305) 264-8100 FAX. (305) 262-6978
 COMP-ANL W17-43ENV

SERIES ENV-350 INSWING ENTRANCE DOOR (L.M.I.)
ENVRALUM INDUSTRIES INC.
 5100 N.W. 72 AVENUE BLDG. C
 MIAMI, FL. 33166
 TEL. (305) 752-4411 FAX. (305) 406-3877

revisions:	no	date	by	description

date: 04-11-17
 scale: 3/8" = 1"
 dr. by: TARIQ
 chk. by:

drawing no.
W17-43
 sheet 8 of 10

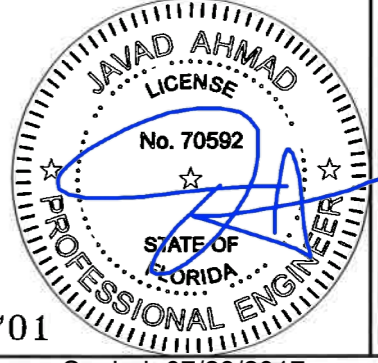

FL #20701

Sealed: 07/28/2017

HINGE OPTION #1:

4" X 4-1/2" X .130" THK. ST. STEEL KNUCKLE HINGE SERIES 4001 BY 'REGENT HARDWARE' OR SERIES FBB 191 BY 'STANLEY SECURITY SOLUTIONS' OR SERIES TA2314/TA2714 BY 'MCKINNEY ASSA ABLOY' 3 PER LEAF
TOP/BOTTOM HINGES AT 7" FROM EACH END
CENTER HINGE AT MIDSPAN
FASTENED TO
FRAME JAMB WITH (4) 12-24 X 1/2" FH MS
DOOR STILE WITH (4) 12-24 X 1/2" FH MS

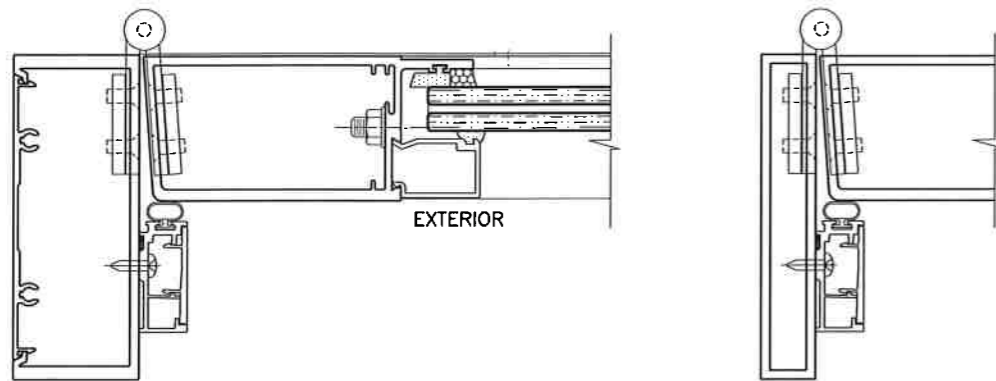

HINGE OPTION #2:

CONTINUOUS GEAR ALUMINUM HINGE PEMKO-FS & SELECT SL-21
FASTENED TO
FRAME JAMB WITH #12 X 3/4" FH SCREWS AT 6" O.C.
DOOR STILE WITH 1/4-20 X 1-1/4" FH MS WITH SEX BOLT AT 6" O.C.

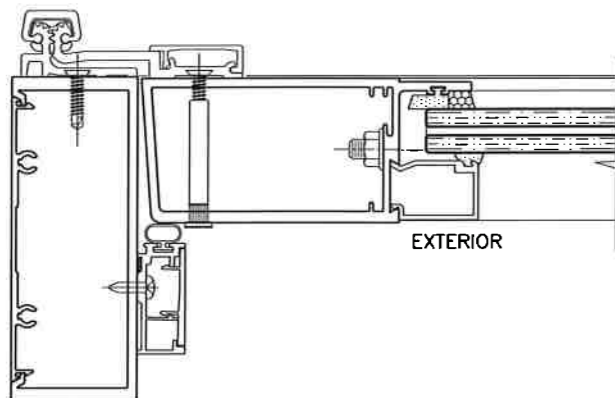

HINGE OPTION #3:

CONTINUOUS ALUMINUM ROTTON HINGE 'PEMKO-FM' OR 'SELECT SL 27'
FASTENED TO FRAME JAMB AND TO JAMB STILE WITH
(22) #12-24 X 1/2" FH MS SCREWS

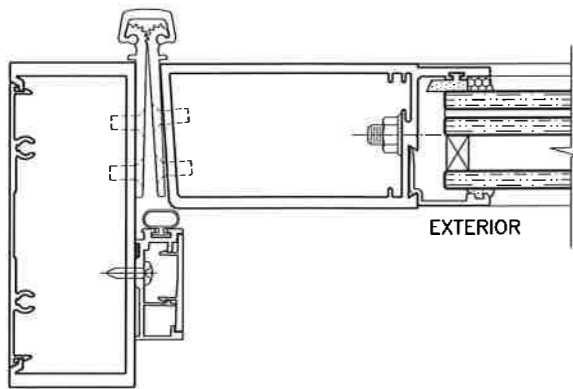

ITEM NO.	PART NUMBER	QUANTITY	DESCRIPTION	MATERIAL	MANF./SUPPLIER/REMARKS
1	ENV-351	1/ LEAF	TOP RAIL	6063-T6	ENVIRALUM
2	ENV-352	1/ LEAF	BOTTOM RAIL	6063-T6	ENVIRALUM
2.1	ENV-3521	1/ LEAF	ALT. BOTTOM RAIL (10" HIGH)	6063-T6	ENVIRALUM
3	ENV-353	1/ LEAF	HINGE STILE	6063-T6	ENVIRALUM
4	ENV-354	1/ LEAF	LOCK STILE	6063-T6	ENVIRALUM
5	ENV-355	2/ DOOR	FRAME JAMB	6063-T6	ENVIRALUM
5A	-	2/ DOOR	ALT. FRAME JAMB	6063-T6	ENVIRALUM
6	ENV-356	1/ DOOR	FRAME HEAD	6063-T6	ENVIRALUM
7	ENV-357	4/ LITE	GLASS STOP (INSULATED GLASS)	6063-T6	ENVIRALUM
8	ENV-358	4/ LITE	GLASS STOP (LAMINATED GLASS)	6063-T6	ENVIRALUM
9	ENV-359	AS REQD.	ADA THRESHOLD RAMP	6063-T6	ENVIRALUM
9.1	ENV-3520	AS REQD.	ADA THRESHOLD RAMP	6063-T6	ENVIRALUM
10	ENV-3510	AS REQD.	THRESHOLD/DOOR STOP COVER	6063-T6	ENVIRALUM
10.1	ENV-3518	AS REQD.	ALT. THRESHOLD COVER (HI-RISE)	6063-T6	ENVIRALUM
11	ENV-3511	1/ DOOR	THRESHOLD	6063-T6	ENVIRALUM
11.1	ENV-3519	1/ DOOR	ALT. THRESHOLD	6063-T6	ENVIRALUM
12	ENV-3512	3/ DOOR	DOOR STOP	6063-T6	ENVIRALUM
13	ENV-3513	AS REQD.	STILE REINFORCEMENT, REQD. FOR DOORS ABOVE 8 FT. HIGH	6063-T6	ENVIRALUM
14	ENV-3515	4/ TRANSOM	TRANSOM SASH	6063-T6	ENVIRALUM
15	ENV-ST2	AS REQD.	1" X 4-1/8" X 1" X 3/16" THK. CHANNEL	STEEL	ENVIRALUM
16	ENV-3516	1/ LEAF CORNER	SHEAR BLOCK	6063-T6	ENVIRALUM
17	ENV-GC01	2/ LEAF	GUIDE CHANNEL FOR TOP & BOTTOM PIN	6063-T6	ENVIRALUM
18	ENV-454	AS REQD.	FLAT SNAP, 3" LONG	6063-T6	ENVIRALUM
19	ENV-3514	AS REQD.	MID-RAIL (OPTIONAL)	6063-T5	ENVIRALUM
21	ENV-G04	AS REQD.	INTERIOR GASKET	EPDM	GLAZING RUBBER PRODUCTS
22	ENV-G06	AS REQD.	SPACER GASKET	EPDM	GLAZING RUBBER PRODUCTS
22A	ENV-G06	1/ QUARTER POINT	SPACER GASKET, 1" LONG	EPDM	GLAZING RUBBER PRODUCTS
23	ENV-SB01	1/ QUARTER POINT	3/8" X 1/2" X 2" SETTING BLOCKS, DUROMETER 80±5	EPDM	GLAZING RUBBER PRODUCTS
24	ENV-SB02	1/ QUARTER POINT	3/8" X 1-1/4" X 2" SETTING BLOCKS, DUROMETER 80±5	EPDM	GLAZING RUBBER PRODUCTS
25	DOW 791	AS REQD.	GLAZING COMPOUND	SILICONE	DOW CORNING
26	GE SCS2000	AS REQD.	GLAZING COMPOUND	SILICONE	GE MOMENTIVE
27	#12 X 1-1/2	4/ CORNER	FRAME ASSEMBLY SCREWS	ST. STEEL	HWH SMS, AT 16" O.C.
28	#8 X 5/8"	AS REQD.	TRANSOM SASH SCREWS	ST. STEEL	AT 3" FROM ENDS & 12" O.C.
29	#8 X 5/8"	AS REQD.	DOOR STOP ASSEMBLY SCREWS, 3" FROM ENDS & 20" O.C.	ST. STEEL	HWH SMS
30	ENV-BP1	2/ HINGE	HINGE BACKING PLATE, 1-1/2" X 1/4" THK. X 8-3/8" LONG	ALUMINUM	-
31	-	AS REQD.	4-1/2" X 4" BUTT HINGES	ST. STEEL	-
32	SL-21	1/ LEAF	CONT. GEAR HINGE	ALUMINUM	SELECT PRODUCTS LTD.
32A	PEMKO-FS	1/ LEAF	CONT. GEAR HINGE	ALUMINUM	PEMKO
33	1/4-20 X 1"	10/ LEAF	CORNER BLOCK ASSEMBLY	ST. STEEL	HEX HEAD BOLT W/ WASHER
34	ENV-G01	AS REQD.	FIXED INTERIOR GASKET	EPDM	GLAZING RUBBER PRODUCTS
37	ENV-WP1	AS REQD.	WOOL PILE W'STRIPPING	TRILOBAL YARN	ULTRAFAB
38	ENV-WP2	AS REQD.	WOOL PILE W'STRIPPING	TRILOBAL YARN	ULTRAFAB
39	ENV-BG1	AS REQD.	BULB W'STRIPPING, (.475 BULB W/ FLAP X .270 BK.)	EPDM	ULTRAFAB

SEALANTS:

ALL FRAME CORNERS, JOINTS, MULLION SEAMS AND PERIMETER OF GLAZING BEAD TO FRAME SEALED WITH SILICONE SEALANT.

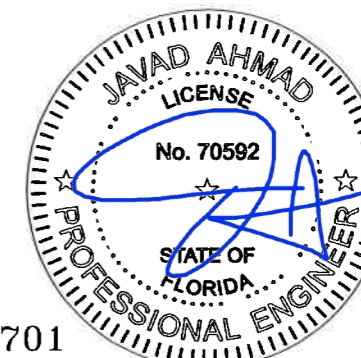

FL #20701

Sealed: 07/28/2017

af c
AL-FAROOQ CORPORATION
ENGINEERS & PRODUCT DEVELOPMENT
9360 SUNSET DRIVE, SUITE 220
MIAMI, FLORIDA 33173 (C.A.N. 3538)
TEL. (305) 262-6978 FAX. (305) 264-8100

SERIES ENV-350 INSWING ENTRANCE DOOR (L.M.I.)

ENVIRALUM INDUSTRIES INC.
5100 N.W. 72 AVENUE BLDG. C
MIAMI, FL. 33166
TEL. (305) 752-4411 FAX. (305) 406-3877

no	date	by	description

date: 04-11-17
scale: 3/8" = 1"
dr. by: TARIQ
chk. by:

drawing no.
W17-43

sheet 9 of 10

COMP-ANL\W17-43ENV

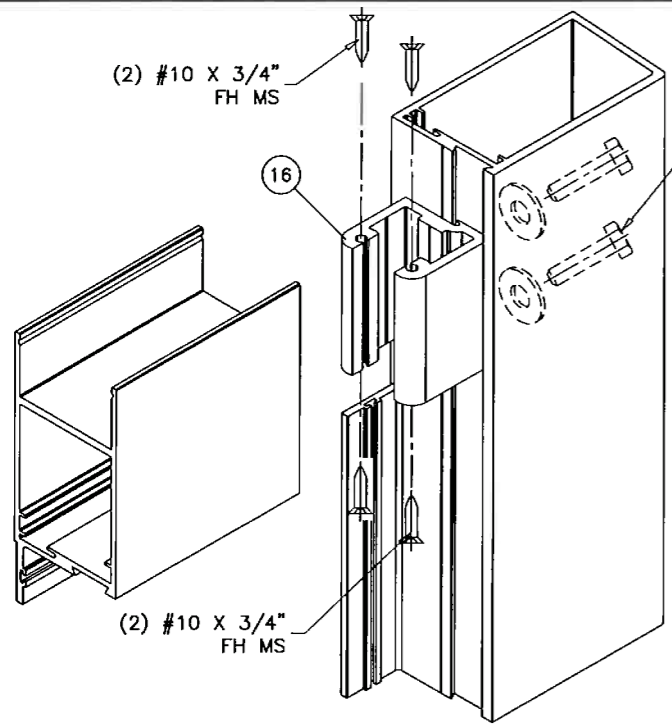

DOOR LEAF TOP CORNER

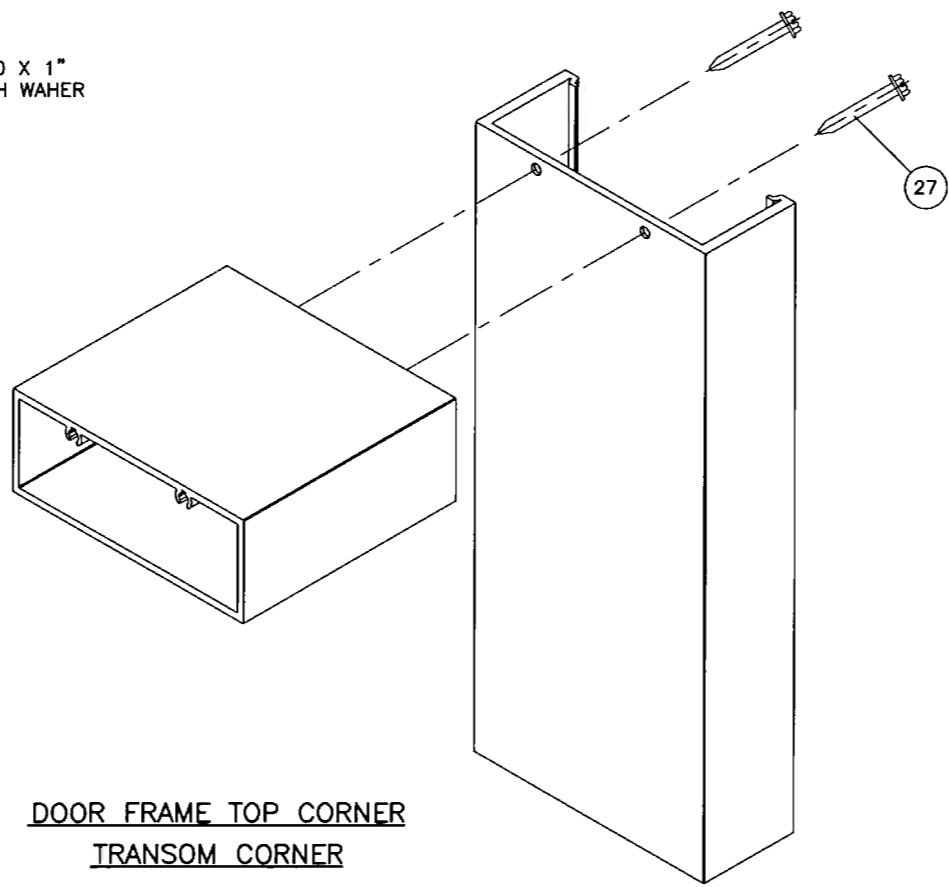

DOOR FRAME TOP CORNER
TRANSOM CORNER

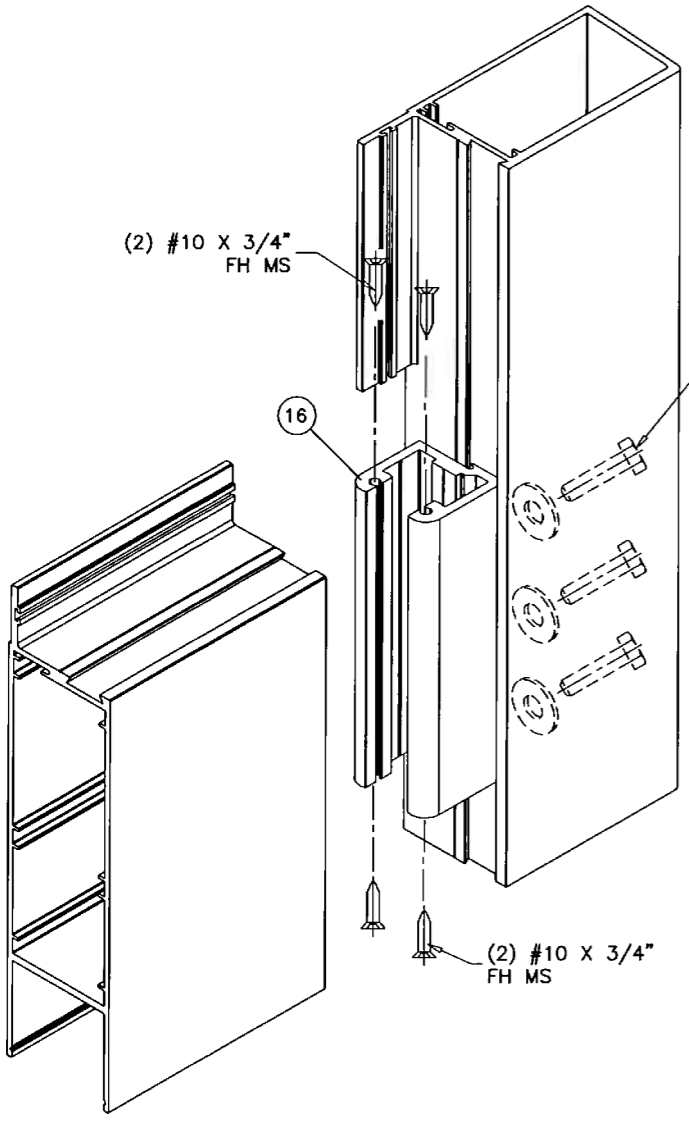

DOOR LEAF BOTTOM CORNER

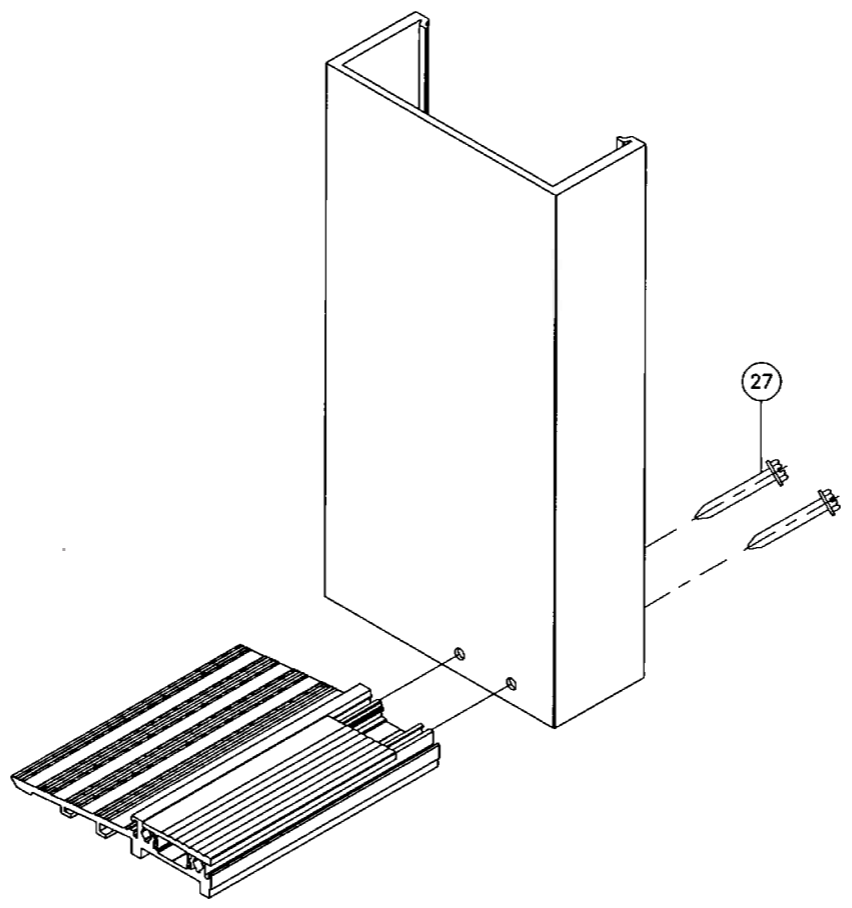

DOOR FRAME BOTTOM CORNER

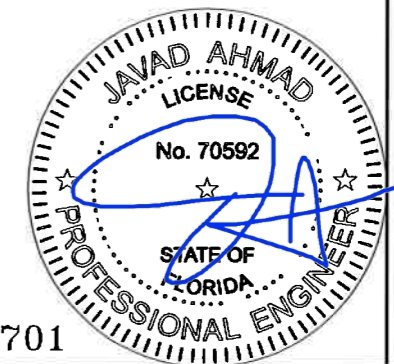
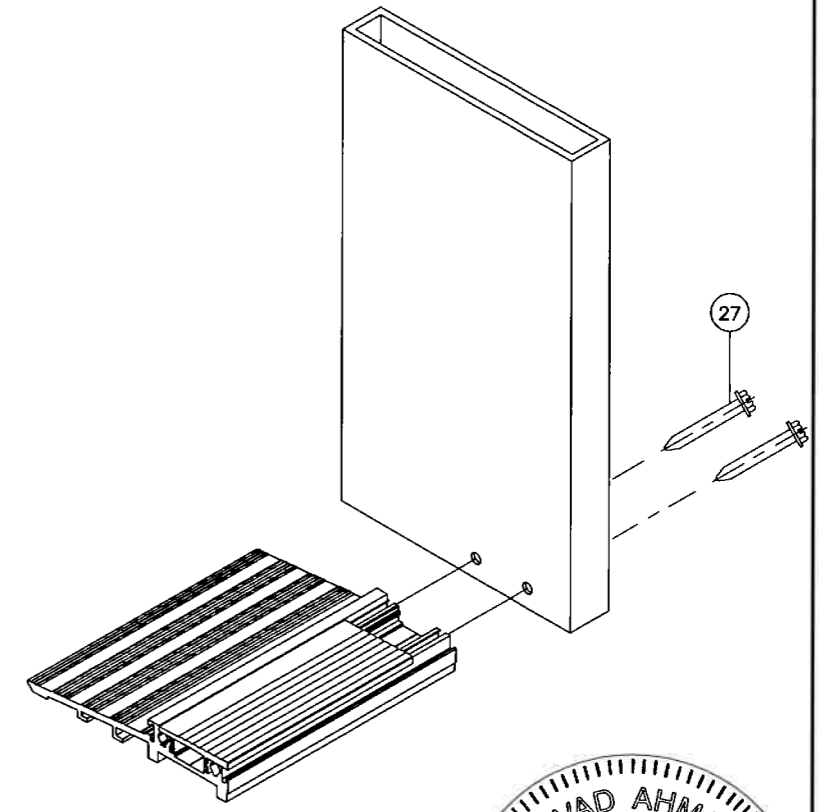

FL #20701

Sealed: 07/28/2017

afc
AL-FAROOQ CORPORATION
 ENGINEERS & PRODUCT DEVELOPMENT
 9360 SUNSET DRIVE, SUITE 220
 MIAMI, FLORIDA 33173 (C.A.N. 3538)
 TEL. (305) 264-8100 FAX. (305) 262-6978
 COMP-ANL W17-43ENV

SERIES ENV-350 INSWING ENTRANCE DOOR (L.M.I.)
ENVIRALUM INDUSTRIES INC.
 5100 N.W. 72 AVENUE BLDG. C
 MIAMI, FL. 33166
 TEL. (305) 752-4411 FAX. (305) 406-3877

revisions:	no	date	by	description

date: 04-11-17
 scale: 3/8" = 1"
 dr. by: TARIQ
 chk. by:

drawing no.
W17-43
 sheet 10 of 10